









Installation Operation Maintenance

Multipipe Chiller RTMA

-  Up to Class A
-  Screw compressors
-  Axial fans
-  Condensing coil fins
-  Outdoor installation
-  Refrigerant R410a



WARNING

Trane has compiled the content to the best of their knowledge. No express or implied warranty is given for the completeness, accuracy, reliability of the content.

All data and specifications contained therein are subject to change without notice. WHEREOF the data communicated at the time of the order.

Trane explicitly rejects any liability for any direct or indirect damage, in the broadest sense of the term, arising from or related to the use and / or interpretation of this publication.

All content is copyrighted by Trane.

Symbol Legend



Important to note that failure to comply may result in damage to the unit or compromising functionality.



Note about safety in general or the compliance with laws and regulations



Note on electrical safety

Index

1. General Information

- 1.1 Delivery of the unit
- 1.2 Checks
- 1.3 Purpose of the manual
- 1.4 General warning
- 1.5 Unit identification
- 1.6 Summary of guarantee regulations

2. Mechanical Installation

- 2.1 Shipping
- 2.2 Responsibility
- 2.3 Safety
- 2.4 Handling and lifting
- 2.5 Operating limits
- 2.6 Handling
- 2.7 Positioning
- 2.8 Minimum space requirements
- 2.9 Installation
- 2.10 Safety regulations
- 2.11 General precautions
- 2.12 Water piping
- 2.13 Water treatment
- 2.14 Antifreeze protection on the heat exchangers
- 2.15 Flow switch installation
- 2.16 Hydraulic data
- 2.17 Hydronic kit
- 2.18 Refrigerating circuit safety valves
- 2.19 Heat exchanger pressure drop
- 2.20 Control and safety calibration

3. Electrical Installation

- 3.1 Electrical data
- 3.2 Electrical components
- 3.3 Electrical connections

4. Unit working

- 4.1 Operator responsibilities
- 4.2 Unit description
- 4.3 Operating modes
- 4.4 Compressor oil load
- 4.5 Cooling/heating capacity control

5. Pre start up checks

- 5.1 General
- 5.2 Electrical supply
- 5.3 Startup preliminary procedures
- 5.4 Check list
- 5.5 Refrigerant replacement procedure
- 5.6 Refrigerant loading

6. Start up

- 6.1 Preliminary checks
- 6.2 Start up
- 6.3 Start up of the plant per unit
- 6.4 Start-up procedure

7. System Maintenance

- 7.1 General
- 7.2 Maintenance
- 7.3 Sight check of the under pressure vessels state
- 7.4 Standard controls
- 7.5 Unit test sheet
- 7.6 Recommended spare parts
- 7.7 Improper use
- 7.8 Ordinary maintenance
- 7.9 Dehydration filter repositioning
- 7.10 Oil filter repositioning
- 7.11 Disposal

8. Service and limits of the warranty

9. Important information regarding the refrigerant used

10. Plant Sketchs

- 10.1 Plant sketches standard version
- 10.2 Plant sketches for single pump version
- 10.3 Plant sketches for single pump + stand by pumps version
- 11.4 Hydraulic connections

11. Dimensional Drawing and weight

12. Troubleshooting

1. General Information

▲ WARNING

The machines covered by this manual represent an excellent investment and deserve attention and care both for correct installation is to keep them in good working order.

It is strongly recommended to sign a maintenance contract with an authorized service center to ensure an efficient and trouble-free.

▲ WARNING

This manual describes the features and procedures common to the whole number of units.

All units are shipped accompanied by schematic and Dimension drawing, dimensions and weights, which are characteristic of the specific machine.

WIRING AND OVERALL DESIGN OF SPECIFIC TO BE CONSIDERED AS AN INTEGRAL PART OF THIS MANUAL.

In case of discrepancy between this manual and the two documents cited prevail as shown on the wiring diagram and outline drawing.

1.1. Delivery of the unit

The machine must be inspected for any possible damage immediately upon reaching its final place of installation. All components described in the delivery note must be carefully verified and checked; any damage must be reported to the transporter. Check on the machine nameplate, before connecting it to earth, that the model and power supply voltage are as ordered. Responsibility for any damage after acceptance of the machine cannot be attributed to Trane.

1.2. Checks

Please perform the following checks upon receipt of the machine, for your protection in the event that it is incomplete (any missing parts) or has incurred damage during transport:

- a) Before accepting the machine, please verify every single component in the consignment. Check for any damage.
- b) In the event that the machine has been damaged, do not remove the damaged material. A set of photographs are helpful in ascertaining responsibility.
- c) Immediately report the extent of the damage to the transporter and immediately request that they inspect the machine.
- d) Immediately report the extent of the damage to the Trane representative, so that arrangements can be made for the required repairs. In no case must the damage be repaired before the machine has been inspected by the representative of the transportation company.
- e) On receiving the unit it is up to the customer to check that there is no obvious damage or pieces missing. If this is so, an immediate complaint must be made to the carrier for damage or for not-delivery and the Receiving Card to be found inside the unit electrical panel must be filled in. Photographic evidence must be provided for macroscopic damage. The card must be sent to Trane within 8 days of receiving the goods: if it is not sent back or delayed, the complaint will not be accepted..

1.3. Purpose of the manual

The purpose of this Manual is to allow the installer and the qualified operator to carry out all required operations in order to ensure proper installation and maintenance of the machine, without risking any damage to people, animals and/or objects.

This Manual is an important supporting document for qualified personnel but it is not intended to replace such personnel. All activities must be carried out in compliance with local laws and regulations.

1.4. General warning

This publication has been prepared only as a support and does not constitute a binding offer to Trane. Trane has compiled the content to the best of their knowledge. No express or implied warranty is given for the completeness, accuracy, reliability of the content. All data and specifications in it shown are subject to change without notice. Trane explicitly rejects any liability for any direct or indirect damage, in the broadest sense of the term, arising from or related to the use and / or interpretation of this publication. All content is copyrighted by Trane .

1.5. Unit identification

The unit is identifiable through:

- Packaging label: the identification data of the product.
- Tecnica Label: the technical data of the product.

If you lose ask a duplicate request to the After Sales Service.

Tampering with, removal, lack of identification markings or anything else does not allow reliable identification of the product, makes it hard for any installation and maintenance.

LABEL

The unit is identified by the a label.

It contains the kind of the unit (serial and size), the serial number, the production year, the electric data, the main technical data, logo anche manufacturer address.

In case of loss request for a duplicate to the after sale service.

Tampering and/or rehandling the label does not allow the identification of the product, and makes difficult any installation and maintenance operation.

SERIAL NUMBER

The serial number identifies the unit unambiguously, it permit to identify the specific characteristic of the unit and the installed components. Without this code it is not possible identifies the specific spare parts of the unit. In case of request for repair it is necessary the model and the serial number.

Thermal Performance

Trane units are tested at the factory, in separate stations, according to an internal procedure. Each performance verification performed on the system is only possible if they are reproduced and maintained in the same conditions (constant load, constancy of temperatures and flow rates of evaporation - condensation and recovery, quality and tolerance of the measuring instruments, etc..) Of the salt test.

The test conditions are those specified by the customer when ordering: in the absence of precise information you should refer to the nominal values specified in the technical bulletin in force on the date of the Order Confirmation..

1.5.1. Product identification code

The encoding of **RTMA** is simple and follows the rules defined by Trane for all other units:

Digit																											
1	2	3	4	5	6	7	8	9	10	11	12	13	14	15	16	17	18	19	20	21	22	23	24	25	26	27	28
R	T	M	A	1	3	0	S	1	1	1	1	1	1	1	1	2	1	1	1	1	1	1	1	1	1	1	1

Digits 1 to 4: RTMA = Screw compressor unit for Multi-pipe application

Digits 5 to 7 = Nominal tonnage

- 105 Tons - 368.7 kW
- 115 Tons - 407.7 kW
- 120 Tons - 426.0 kW
- 130 Tons - 463.5 kW
- 150 Tons - 529.2 kW
- 170 Tons - 594.2 kW
- 180 Tons - 626.2 kW
- 190 Tons - 666.3 kW
- 210 Tons - 733.0 kW

Digit 8 = Acoustics
 X Standard Noise
 L Low Noise
 S Super Low Noise

Digit 9 = Hydraulic version
 X Without (Standard)
 1 Cooling + Heating circuit pump 150 kPa
 2 Cooling + Heating circuit pump 250 kPa
 3 Cooling + Heating circuit pump 450 kPa
 4 Std by pump Cooling + Heating circuit pump 150 kPa
 5 Std by pump Cooling + Heating circuit pump 250 kPa
 6 Std by pump Cooling + Heating circuit pump 450 kPa

Digit 10 = Remote control display
 X Without (Standard)
 1 With Remote Control Display

Digit 11 = Power factor correction
 X Without (Standard)
 1 Cos Phi = 0.91

Digit 12 = Control panel electric heater with thermostat
 X Without (Standard)
 1 With

Digit 13 = Phase failure protection relay
 1 With (Standard)

Digit 14 = Communication card RS485
 1 With (Standard)

Digit 15 = Soft starter
 X Without (Standard)
 1 With

Digit 16 = Automatic circuit breaker
 X Without (Standard)
 1 With

Digit 17 = Condensing control
 X Standard
 1 With variable fan speed modulation
 2 EC Fans

Digit 18: Numbered wires
 X Without (Standard)
 1 With

Digit 19: Flow switch
 X Without (Standard)
 1 With

Digit 20 = Automatic water filling
 X Without (Standard)
 1 With

Digit 21 = Water strainer
 X Without (Standard)
 1 With

Digit 22 = Water gauges
 X Without (Standard)
 1 With

Digit 23 = Gas gauges
 X Without (Standard)
 1 With

Digit 24 = Condensing coil protection grilles
 X Without (Standard)
 1 With

Digit 25 = Isolators
 X Without (Standard)
 1 Rubber anti vibration mounts
 2 Spring anti vibration mounts

Digit 26 = Compressor sound jacket attenuator
 X Without (Standard)
 1 With

Digit 27 = Condensing coil
 1 Aluminum (Standard)
 2 Aluminum + Blygold condensing coils
 3 Aluminum Pre painted condensing coils
 4 Aluminum Epoxy coated condensing coils
 5 Copper/Copper condensing coils
 6 Tinned copper/copper condensing coils

Digit 28 = High temperature Hot leaving water (HPT)
 X Without (Standard)
 1 With

1.6. Summary of guarantee regulations

- A. The guarantee for Trane machines is 12 months from the date the machine is operated for the first time but no more than 18 months from the date of the invoice. The warranty is reduced to 6 months from the start up date for units running continuously, that is more than 12 hours a day. The date the machine is operated for the first time means the date reported in the "1st start up form" contained into the "machine log book". This form should be filled in and sent, within 8 days from the start up, to Trane.
- B. The guarantee is valid if all the installation regulations have been adhered to (both those which may have come from Trane and those coming from current practice), if the "1st start up form" has been filled in and sent to the Trane after sales department.
- C. The guarantee is subject to any faults or defects being reported within eight days from their discovery. The guarantee will only be applied if and when the purchaser suspends use of the equipment as soon as a defect has been found.
- C1. Repositioning items are to be considered always ex TRANE factory. Labour costs to replace failed items either under warranty or not, will be not of TRANE care.
- D. The guarantee is valid if the first running of the machine is carried out by a Trane authorised assistance centre.**
- E. The guarantee is subject to regular maintenance of the unit which is appropriately indicated in the "machine log book" located inside the electrical panel.
- F. Warranty is automatically over in case of payments not fulfilled, non-performance of the contract and even if the units show tampering without TRANE writing approvals.
- G. Non observance of the above mentioned rules and of all the indications written on this manual, will cause the immediate loss of warranty, getting free TRANE from any responsibility for the unit and any damages to persons or things.

2. Mechanical Installation

2.1 Shipping

The stability of the machine during shipping must be ensured. If the machine is shipped with a wooden cross-plank on its base, this cross-plank must only be removed after the final destination has been reached.

2.2 Responsibility

ThermoCld declines all present and future responsibility for any damage to persons, animals or things caused by negligence of operators failing to follow the installation and maintenance instructions in this Manual. All safety equipment must be regularly and periodically checked in accordance with this manual and with local laws and regulations regarding safety and environment protection.

2.3 Safety

The machine must be securely fixed to the ground.

It is essential to observe the following instructions:

- **The machine can only be lifted using the hoist points marked in yellow that are fixed to its base. These are the only points that can support the entire weight of the unit.**
- **Do not allow unauthorised and/or unqualified personnel access to the machine.**
- **It is forbidden to access the electrical components without having opened the machine's main switch and switched off the power supply.**
- **It is forbidden to access the electrical components without using an insulating platform. Do not access the electrical components if water and/or moisture are present.**
- **All operations on the refrigerant circuit and on components under pressure must be carried out only by qualified personnel.**
- **Repositioning of a compressor or addition of lubricating oil must be carried out only by qualified personnel.**
- **Sharp edges and the surface of the condenser section could cause injury. Avoid direct contact.**
- **Switch off the machine's power supply, by opening the main switch, before servicing the cooling ventilators and/or compressors. Failure to observe this rule could result in serious personal injury.**
- **Avoid introducing solid objects into the water pipes while the machine is connected to the system.**
- **A mechanical filter must be applied to the water pipe to be connected to the heat exchanger inlet.**
- **The machine is supplied with safety valves, that are installed both on the high-pressure and on the low-pressure sides of the refrigerant gas circuit.**

⚠ WARNING

Before carrying out any operation on the machine, please read the instruction and operating manual. Installation and maintenance must be carried out solely by qualified personnel that is familiar with local rules and regulations and has experience with this type of equipment. Installation of the machine must be avoided in any place that could be considered dangerous during maintenance procedures.

⚠ WARNING

The installation of the machine must be avoided in any place that can be considered dangerous during maintenance, such as (but not only) covers without parapets or railings or without proper clearances.

2.4 Handling and lifting

Avoid bumping and/or jolting during unloading from the lorry and handling the machine. Do not push or pull the machine from any part other than the base frame. Block the machine from sliding inside the lorry in order to prevent damage to the panels and to the base frame. Avoid any part of the machine falling during unloading and/or handling, as this could cause serious damage.

2.5 Operating limits

2.5.1 Storage

The units can be stored within the following environmental conditions:

Min ambient Temperature	:	-10°C
Max ambient Temperature	:	53°C
Max. Relative Humidity	:	95% not condensable

WARNING

Storage at temperatures below the minimum specified can cause damage to some parts including the electronic controller and its LCD display.

WARNING

Storage at temperatures above the maximum indicated causes the opening of the safety valves placed on the suction line of compressors.

WARNING

The storage in the atmosphere condensed can damage electronic components.

2.5.2 Working

The operation of the units is permitted within the limits indicated in the following diagram

WARNING

The operation outside the limits specified may cause the operation of the protections and disrupt the operation of the unit and, in extreme cases, damaged

In case of doubt, consult the factory.

These operating limits apply to machine operating at full load

2.5.3 OPERATING RANGE

Version	Operating way	Ta		Tw out	
		Min	Max	Min	Max
Std-SL	Cooling	18	43	-8 ⁽¹⁾	18
Std-SL	Heating	-15	30	25	60/65 ⁽²⁾

(1) Operation with glycol

(2) Units equipped with accessory HPT (High Performance Temperature), with temperatures of producing water of 65 °C.

Ta = Outdoor air temperature (°C)

Tw out = Outlet water temperature (°C)

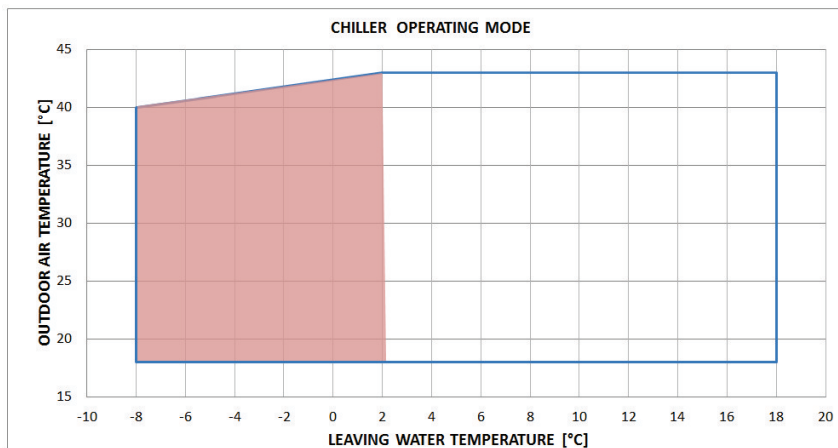

 ONLY WITH GLYCOL

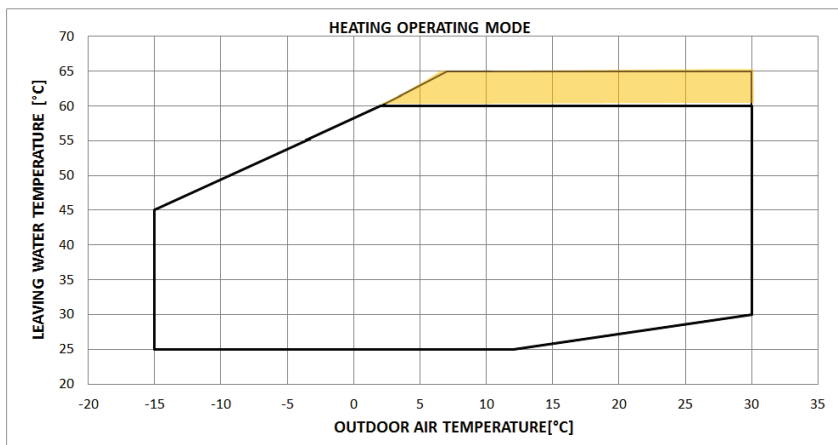

 HPT

HPT = Units equipped with the accessory High Performance temperature (HPT), with outlet water temperature up to 65°C.

Beware the air condition is meant as absence of air flow to the unit. Wind condition can let air flow through the condenser coil causing a reduction in the operating limit. In the case of predominant winds, it becomes necessary the use of appropriate wind barriers

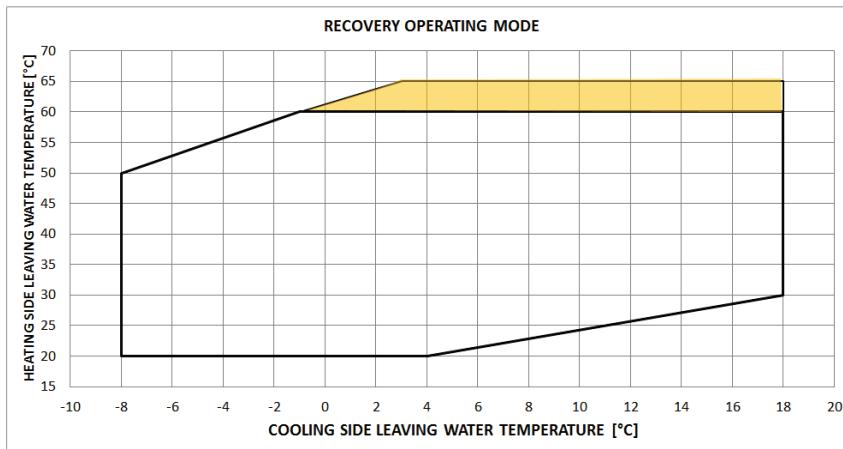

HPT

HPT = Units equipped with the accessory High Performance temperature (HPT), with outlet water temperature up to 65°C.

Beware the air condition is meant as absence of air flow to the unit. Wind condition can let air flow through the condenser coil causing a reduction in the operating limit. In the case of predominant winds, it becomes necessary the use of appropriate wind barriers

2.6 Handling

Handling RTMA

Check the weight of the unit 'and the ability' to load the lifting device. Be careful when handling the obstacles placed in the path that may damage the units' (bumps, ramps, hills, etc. ...)

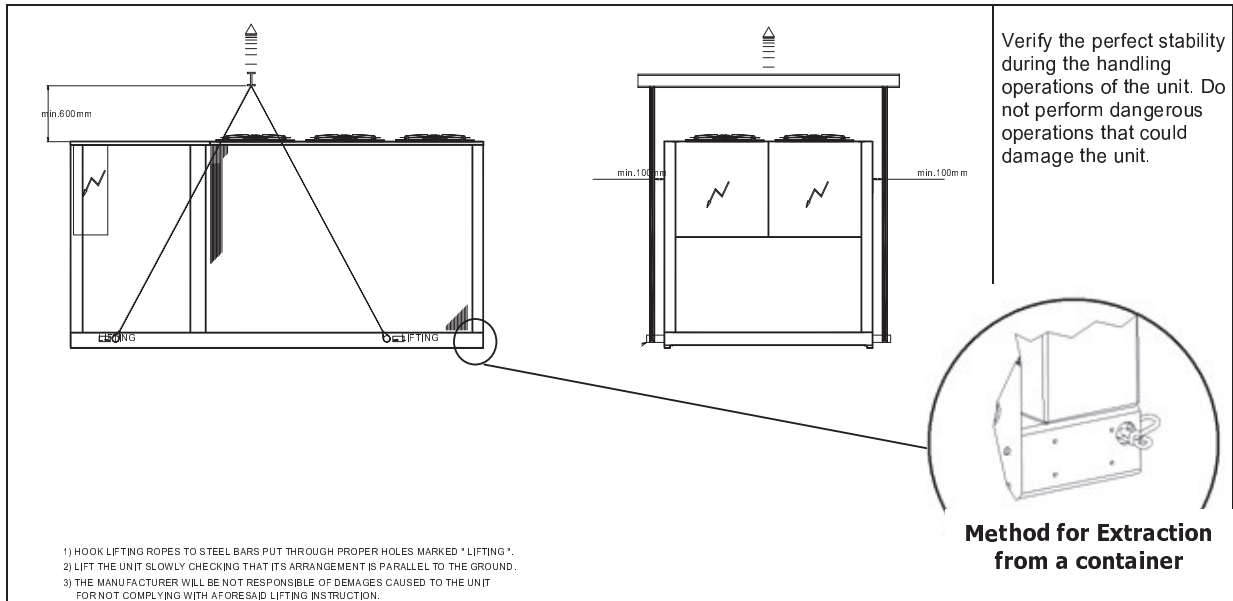

Verify the perfect stability during the handling operations of the unit. Do not perform dangerous operations that could damage the unit.

Method for Extraction from a container

- 1) HOOK LIFTING ROPES TO STEEL BARS PUT THROUGH PROPER HOLES MARKED ' LIFTING '.
- 2) LIFT THE UNIT SLOWLY CHECKING THAT ITS ARRANGEMENT IS PARALLEL TO THE GROUND.
- 3) THE MANUFACTURER WILL BE NOT RESPONSIBLE OF DAMAGES CAUSED TO THE UNIT FOR NOT COMPLYING WITH AFORESAID LIFTING INSTRUCTION.

Make sure that during transport the mece not arrive in positions previtse. Positionings momentarily horizontal unit 'can lead to irreversible damage to the compressors. Faultiness' arising from incorrect transport will not be under warranty by the manufacturer. Immediately report an incorrect receipt of goods. An arrow positioned upward, indicating the vertical position of the unit

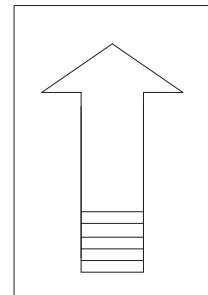

⚠ WARNING

Both the lifting ropes that the spreader bar and / or balance must be sized to hold the weight of the machine safely. Check the weight of the unit on the nameplate of the machine.

The weights given in the tables "Technical data" in the "General Information" refers to standard units, without any additional optional.

The machine may have specific accessories that increase the overall weight (pumps, copper / copper, etc..).

⚠ WARNING

The machine must be lifted with the utmost attention and care. Avoid abrupt lifting lifting the machine very slowly and well leveled.

2.7 Positioning

Positioning and installation

All Isa-4 units are produced for installation outdoors, on balconies or on the ground, provided that the area is free from obstacles that could hamper air flow towards the condenser batteries.

The machine must be installed on a robust and perfectly level foundation; should the machine be installed on balconies and/or attics, it could be necessary to use weight distribution beams.

For installation on the ground, a strong cement base that is at least 250 mm wider and longer than the machine must be foreseen. Also, this base must be able to support the weight of the machine as declared in the technical specifications.

If the machine is installed in places that are easily accessible for people and animals, it is advisable to install battery and compressor section protection grates.

To ensure the best possible performance on the installation site, the following precautions and instructions must be followed:

- Avoid air flow recirculation
- Make sure that there are no obstacles to hamper air flow.
- Air must circulate freely to ensure proper intake and expulsion.
- Ensure strong and solid flooring to reduce noise and vibrations as much as possible.
- Avoid installation in particularly dusty environments, in order to reduce soiling of condenser batteries.
- The water in the system must be particularly clean and all traces of oil and rust must be removed. Installation of a mechanical water filter is required for the machine's input piping.

2.8 Minimum space requirements

Dimensional drawing shall be respected. If you do not respect it, may happen:

- Noise
- Not correct heat exchange and ventilation
- Hard maintenance or not accessible

It is fundamental to respect minimum distances on all Trane units, in order to ensure optimum ventilation for the condenser batteries. Limited installation space could reduce the normal air flow, thus significantly reducing the machine's performance and considerably increasing consumption of electrical energy.

When deciding where to position the machine and to ensure a proper air flow, the following factors must be taken into consideration: avoid any warm air recirculation and insufficient supply to the air-cooled condenser.

Both these conditions can cause an increase of condensing pressure, which leads to a reduction in energy efficiency and refrigerating capacity. Thanks to the geometry of their air-cooled condensers, Trane units are less affected by bad air circulation situations.

Also, Trane software has a particular ability for calculating the machine's operating conditions and for optimising the load under abnormal operating conditions.

Every side of the machine must be accessible for post-installation maintenance operations. Figure 3 shows the minimum space required.

Vertical air expulsion must not be obstructed as this would significantly reduce capacity and efficiency.

If the machine is positioned in such a way as to be surrounded by walls or with obstacles of the same height as the machine, it must be installed at a distance of at least 2500 mm. If these obstacles are higher, the machine must be installed at a distance of at least 3000 mm.

Should the machine be installed without observing the recommended minimum distances from walls and/or vertical obstacles, there could be a combination of warm air recirculation and/or insufficient supply to the air-cooled condenser which could cause a reduction of capacity and efficiency.

In any case, the microprocessor will allow the machine to adjust to new conditions by producing the maximum available capacity, even if the lateral distance is lower than recommended.

When two or more machines are positioned side by side, a distance of at least 3600 mm between condenser batteries is recommended.

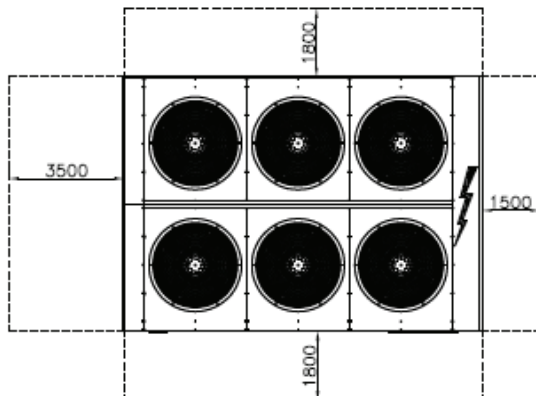

In any case, the microprocessor will allow the machine to adapt to the new condition producing the maximum available capacity (which would, however, lower than the nominal capacity of the machine) even with a lateral distance less than the recommended. When two or more machines are positioned side by side, it is recommended that a minimum distance of 3600 mm of distance between the condenser coils. For more solutions, consult an authorized.

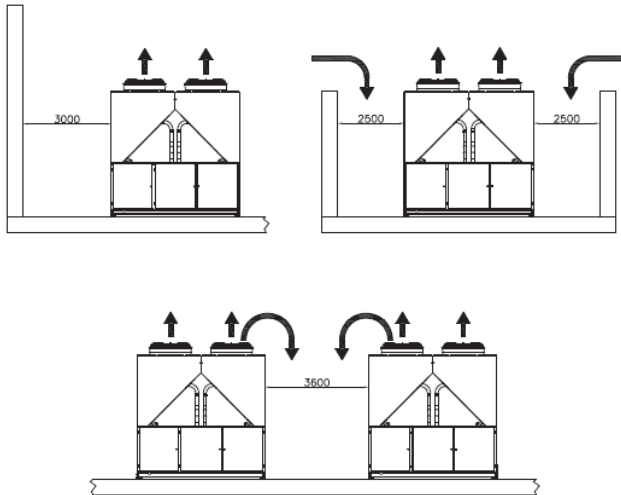

Condensate

The unit in order to easily discharge the condensate caused by the heat pump operation, especially during the defrosting cycle. Avoid the condensate drain in location where people transit.

Anti-vibration

Secure the bottom part of the antivibration to the base unit will support it.
(fix the antivibration bolts)

Screw nut and lock nut to adjust the proper leveling of the unit'. The units 'positioned incorrectly can cause damage to the compressor to incorrect leveling of the' oil.

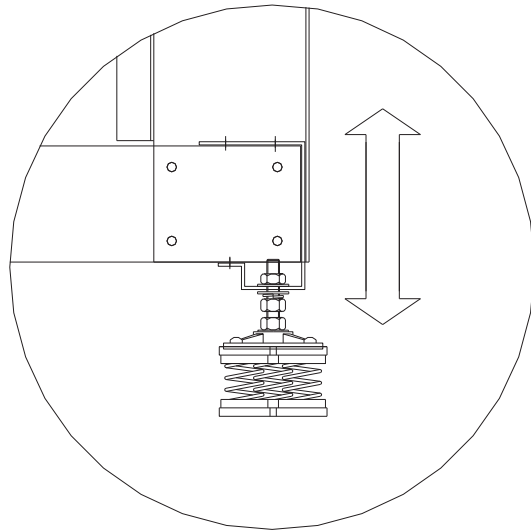

2.9 Installation

Installation side selection

Before installing the unit, agree with the customer the location where it will be placed, placing WARNING the following points:

- the shelf must be able to support the weight of the unit;
- safety distances between the unit and other equipment or structures to ensure that the air in and out from the fans is free to circulate.

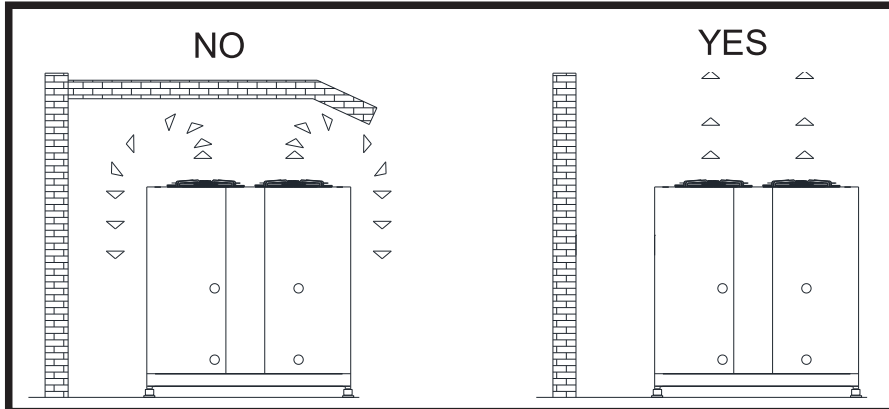

Positioning

Before handling the unit, verify the lifting capacity of the means respecting the information on the packaging.

For handling the unit on horizontal base use forklift or other means in an adequate way paying attention on the unit weight. In case of lifting, insert bars in the proper holes of the unit base in order to permit the positioning of the lifting ropes and of the safety cotter pin.

In order not to damage the unit structure by the belts, use proper protections to be put between the belts and the unit. Position the unit in the place indicated by the client by interposing between the base and the support, a gum mattress (thickness min. 10 mm.) or antivibration feet (optional). Fix the unit verifying that the base is plan and without inclinations.

Verify the easy access to the hydraulic and electric part. In case of installation in places where there could be gust, fixing the unit to the support properly using guy rope if needed.

Handling and positioning

The units have been designed to be lifted from above by means of eyebolts and holes in the base members.

Use retractor bars to keep the lifting wires or chains away from the unit.

Lifting procedures provided with the unit have to be respected.

Precautions for dominant winds

Avoid obstacles on suction and discharge sides of the units. Respect the servicing spaces as shown on the units dimensional drawings.

In case of presence of dominant winds in the installation area it is strictly necessary to avoid (for units with horizontal flow fans) that such winds blow in front of the unit (fans discharge side). In case of unit with vertical flow fans it is strictly necessary to avoid installations where the dominant winds could cause rejected hot air to come back to the condensing coils.

If needed, install windbreak barriers (in this case contact our offices).

Precautions against direct sunshine

The direct sunshine can raise the condensation temperature and it causes the unit stopping or the missing set-up because of the high-pressure switch intervention

Precautions against chimney and hot air discharge

Avoid the unit installation lee side near chimney and liquid and gas discharge.

Attention

Do not use forklift trucks to lift the unit from below.

If equipment for lifting from above is not available, using rollers may move the unit.

The surface on which the unit is placed must be flat and strong enough to withstand the weight of the unit while running.

In order to reduce the transmission of vibrations to the supporting structures, fit shock absorbers in every fastening point. Rubber shock absorbers are recommended for units installed on the ground, spring shock absorbers for units installed on roofs. Open spaces around the unit must be provided for in order to allow for the passage of necessary airflow and in order to allow normal maintenance to be carried out (as shown on general catalogues).

ATTENTION: in case two units have to be installed side by side, the distance of respect must be doubled.

2.10 Safety regulations

Preamble.

All Trane units are designed, built and inspected in compliance with the European Community Directives n° 98/37/CE (three phase power supply), EN 60335 Part 1 and 2, low voltage directive 73/23/CEE, electromagnetic compatibility directive EMC 89/336/CEE, Pressure Equipment Directive 97/23/CEE. Before using the machine read carefully the recommendations reported in the following manual.

Definition

Owner:

The legal representative of the company, body or natural person who owns the plant in which the Trane unit is installed: he or she is responsible for the control and respect of all the safety regulations indicated in this manual as well as the national ones in force.

Installer:

The legal representative of the company appointed by the owner to position and hydraulically, electrically etc. connect the Trane unit to the plant: he or she is responsible for handling and the correct installation of the unit in accordance with the indications in this manual and with the national regulations in force.

Operator:

A person authorised by the owner to carry out all the operations of regulation and control on the Trane unit which are specifically mentioned in this manual. He or she should keep to actions described in the manual and limit his or her action to what is explicitly allowed.

Technician:

A person who is directly authorised by Trane or, secondarily, for all EU countries except for Italy, by the distributor of the Trane product, under their own responsibility, to carry out all ordinary or extraordinary maintenance operations, as well as regulations, controls, repairs and parts repositioning which may be necessary during the lifetime of the unit.

Access to dangerous areas

The access to the unit dangerous areas is usually obstructed through protection panels, which are removable, by using a tool. Axial fans are protected with accident prevention grilles. Centrifugal fans are not protected on the discharge, as they have to be connected to ducts. In case they have to run without ducts, it is the installer duty to provide protection grilles.

Finned coil, for units not equipped with coil protection grilles, is completely accessible with danger for cuts and abrasions. In these cases technicians and operators must be aware about this risk.

For all the units which allow access to the cooling piping or to the packaged condensing coils with fins, without security gratings (optional) or closing panelling, the following precautions must be taken:

- mark the areas with contact risks.
- apply warning signs.

The danger zone must be of a suitable size to avoid any contact, even accidental contact.

In the presence of safety valves without relevant remote controls, the operating area must be of a size which considers a range of action of the discharge flow of 3 metres.

Trane declines any responsibility for damage to things and unauthorised personnel in case of absence of clear and static limiting systems of the risk areas and of the relevant warning and danger signs.

2.11 General precautions

The operator must only intervene on the unit commands; he or she must not open any panels except for the one which gives access to the command module.

The installer must only intervene on the connections between the plant and the machine; he or she must not open any machine panels nor carry out any commands.

The following precautions should be made when approaching or working on the unit:

- Do not wear jewellery, baggy clothes or any other accessory which can get caught up.
- Use appropriate protection (gloves, glasses etc.) when using an open flame (welding) or compressed air.
- If the unit is located in a closed environment, wear hearing protection.
- Before disconnecting, rehandling tubes, filters, joints or other line parts intercept the connection tubes, empty them until the pressure reaches that of the atmosphere.
- Do not use your hands to check for possible pressure losses.
- Always use tools which are in good condition; make sure the instructions have been fully understood before using them.
- Make sure that any tools, electrical cables or other loose objects have been removed before closing the unit and starting it up again.

INSTALLATION OPERATION MAINTENANCE

Precautions against risks due to the refrigerant

Safety data	
Toxicity	Not important
Risks for skin touching	Splashes or sprinkles can cause chill burns. The risk of absorptions through the skin is not relevant..
	Those refrigerants could take some lightly irritating effects and in lliquid stage they have a strong skinning effect. In this case it is necessary to rinse with fresh water the contaminated parts of the skin
	The refrigerant in liquid stage in contact with wet fabries cause freezing and adherence to the skin. In this case it is necessary to put off the contaminated clothes to avoid freezing. Please contact a doctor in case of irritation of the contaminated parts.
Risks for contact with the eyes	Vapors don't take any effect. Splashes or sprinklers can cause chill burns. In those cases it is necessary to rinse the eyes with water or with solution for ocular washings for 10 minutes. The intervention of a doctor is needed.
Risks for ingestion	Should it happen, it causes chill burns. It does not cause vomiting. The person must be kept awake. It is needed to rinse the mouth with fresch water and to drink almosto 0,25 liters. The intervent of a doctor is needed.
Risks for inhalation	High concentration of vapours in air can lead to anaesthetic effects up to a loss of conscience. Long exposures could give rise to cardiac arrhythmia and sometimes even to death.
	High concentrations can create a reduction of oxygen in air, with consequent possibility of suffocation. Should it happen the person must be taken to the open air and let him to take a rest.
	Administer oxigen if needed. In case the breathing has interrupted or become irregular, it is necessary to apply the artificial breathing. In case of cardiac arrest a heart massage must be applied. Contact a doctor immediately.
Conditions to avoid	Use in presence of exposed flames, and of elevates levels of humidity..
Dangerous reactions	Possibility of violent reactions with the sodio, the potassio, the barium and with other alkaline substances, incompatible materials and all the alloys containing more than 2% of magnesium..
Protection wearing - Behavior in case of losses or escapes	Wear protection apparel and self respirators. Insulate the source of the loss, if this operation can be done in safety conditions. Small quantitative of refrigerant escaped at liquid state can be allowed to evaporate only if the room is well ventilated. In case of great losses ventilate the room immediately. Plug the loss with sand, soil or other absorbent material; avoid that the liquid refrigerant can enter in water-drainages or losing pools.
Dismantlemen	The best procedure is the recovery and the recycle. If this is not possible the refrigerant must be conferred to an accredited system for its destruction in order to neutralize acid and toxic by-products..

Precautions against residual risks

Prevention from risks due to the command system

- make sure the instructions for use have been understood before carrying out any work on the control panel.
- always keep the instruction manual close at hand when working on the control panel.
- start up the unit only after having certified that it is correctly connected to the plant.
- inform the technician promptly of any alarms which appear on the unit.
- do not reset the alarms to manual restart without having first identified the cause and removed it.

Prevention against residual mechanical risks

- install the unit in accordance with the provisions of the following manual.
- carry out all the maintenance operations provided for by this manual regularly.
- wear a protective helmet before entering inside the unit.
- before opening a machine panel make sure that it is firmly connected by means of a hinge.
- do not touch the air condensation batteries without having first put on protective gloves.
- do not remove the protections to the handling parts while the unit is running.
- before restarting the unit make sure that the handling part protections are in the correct position.

Prevention against residual electrical risks

- connect the unit to the mains in accordance with the provisions of this manual.
- carry out all maintenance operations regularly.
- before opening the control panel disconnect the unit from the mains by means of the external knife switch.
- check that the unit has been earthen correctly before starting it up.
- control all the electrical connections, the connection cables paying particular attention to the state of isolation; replace the cables which are clearly worn or damaged.
- carry out periodic checks of the wiring inside the panel.
- do not use cables with an inappropriate section or flying connections not even for a limited period or in an emergency.

Prevention against residual risks of a different nature

- the residual risk due to pressure are mainly coming from non functioning of the safety devices. To prevent them it is necessary to follow the checks and repositionings as following indicated (§12.1 and 13)
- to protect from safety devices exhausting it is not allowed to remove the protections while the unit is in operation and to approach the unit without wearing the right protections. In case of accidental contact with refrigerant due to the safety valves exhaust it is necessary to follow the above indicated (§2.5)
- carry out the plant connections to the unit by following the indications reported on the following manual and on the panels of the unit itself.
- if a part is disassembled, make sure that it is correctly reassembled before restarting the unit.
- do not touch the discharge line of the compressor, the compressor itself or any other tube or component which is inside the machine without putting on protective gloves.
- keep a fire extinguisher which is able to put out fires on electrical equipment near the machine.
- on units installed inside, connect the refrigerant circuit shut off valve to a network of tubes which are able to lead the possible spillage of refrigerating fluid outside.
- eliminate any fluid loss inside or outside the unit.
- collect the discharge liquid and clean up any possible oil leakage.
- periodically clean the compressor casing of the accumulated dirt deposits.
- do not keep inflammable liquids near the unit.
- do not dispose of the refrigerant fluid and the lubricating oil in the environment.
- welding should only be carried out on empty tubes; do not approach the tubes containing refrigerant fluid with flames or other sources of heat.
- do not bend or strike tubes containing pressurised fluids.

Also always take the following precautions:

Precautions to be observed during maintenance operations

Authorised technicians may only carry out maintenance operations.

Before carrying out any maintenance the following must be performed:

- isolate the unit from the mains electricity by using the external knife switch.
- place a notice on the external knife switch which says "do not use - maintenance in progress".
- make sure that any possible on-off commands are disabled.
- use appropriate safety equipment (helmet, isolating gloves, protective glasses, safety shoes etc.).

If measurements or controls must be carried out which require the machine to be running the following observations must be followed:

- operate with the electrical panel open for as short a time as is possible.
- close the electrical panel as soon as the individual measurement or control has been carried out.
- for units which are located outside, do not carry out interventions in dangerous atmospheric conditions such as rain, snow, fog etc.

The following precautions should also be taken at all times:

- never dispose of fluids contained in the refrigerant circuit into the environment.
- when replacing an EPROM or electronic card always use appropriate equipment (extractor, anti static bracelet, etc.).
- if a compressor, the evaporator, the condensation batteries or any other heavy part is to be replaced, make sure that the lifting equipment matches the weight to be lifted.
- in the air cooled units with an independent compressor compartment, do not open the ventilator compartment without having first isolated the machine using the knife switch on the side of the panel and only after having placed a sign which says "do not use - maintenance in progress".
- if modifications must be carried out to the cooling, hydraulic or electrical circuit of the unit, as well as to its command logic, contact Trane.
- if particularly complicated assembly or disassembly operations are to be carried out contact Trane.
- always use original spare parts bought directly from Trane or from official dealers of the companies reported in the list of recommended spare parts.
- if the unit is to be moved after a year of being in the site or if it has to be dismantled contact Trane.

Precautions against foliage and external body

Avoid the unit installation nearby plants which could obstacle the correct air charge and discharge.

Warning

Do not use forklift trucks to lift the unit from below.

If equipment for lifting from above is not available, using rollers may move the unit.

The surface on which the unit is placed must be flat and strong enough to withstand the weight of the unit while running. In order to reduce the transmission of vibrations to the supporting structures, fit shock absorbers in every fastening point. Rubber shock absorbers are recommended for units installed on the ground, spring shock absorbers for units installed on roofs. Open spaces around the unit must be provided for in order to allow for the passage of necessary airflow and in order to allow normal maintenance to be carried out (as shown on general catalogues).

ATTENTION: in case two units have to be installed side by side, the distance of respect must be doubled.

Precaution against frost risk of the idraulic pipes

It is necessary to insulate pipes in the plant to avoid extreme heat loss and to protect them from weather conditions.

The problem of wather pipes freezing could appear in two different situations:

- Unit standby, with mode on, but electrically connected: in this case, the unit has frost resistances, which protect the wather locally contained in the exchangers and in the pipes from ice formation. These resistances do not guarantee the protection against the frost in the outdoor connection pipes, to be prevent by frost protection systems. Trane suggest to insert frost thermostatic resistances on every outdoor pipes. In the following table there are the indicative electric power per pipe linear meter:

dn	inch	W/mt
8	1/4"	5
10	3/8"	5
15	1/2"	5
20	3/4"	10
25	1"	13
40	1" 1/2	30
50	2"	50
65	2" 1/2	80
80	3"	120
100	4"	200
125	5"	300
150	6"	450
200	8"	750

- Electrically unconnected unit: in this case the frost resistances of the unit could not guarantee the protection. So it is absolutely necessary unload the unit content for A.C.S., instead for air conditioning it is necessary to add the correct glycol quantity indicated in the chapter: "Ethylenic glycol correction table".

Precaution for very low outdoor temperature

The unit has variable flow pumps on the primary circuit which allow to start with low water temperature in the storages or in the plant, automatically, but the water temperature should not be lower than 10°C. In case of installation conditions with a lower temperature:

1. If there are storages, insert electric resistances to be calculated by :

$$Pr_{Watt} = V \times (10 - t_{min}) / 860$$

where: PrWatt is the resistance power (Watt) and tmin is the lower temperature (°C)

2. If there are not storages, maintain the temperature higher than 10°C the water temperature by inserting termstatic resistance with power calculated as in case 1.

Control of compressor fastening

The compressors are fitted on shock absorbers. After receiving the unit check if there are blockages to fasten the compressors during the transportation. If there are, it is necessary to remove blockages put to fasten the compressors feet before the start-up otherwise the warranty is not valid.

Acoustic Protections

When the sound level must be checked in particular, it is necessary to pay maximum WARNING in isolation from the base of the machine properly applying the anti-vibration mounts (provided optionally). Also, install flexible joints on water connections.

2.12 Water piping

Piping must be designed with the lowest number of curves and the lowest number of vertical changes of direction. In this way, installation costs are reduced considerably and system performance is improved. The hydraulic system should have:

1. Anti-vibration supports in order to reduce transmission of vibrations to the underlying structure.
2. Sectioning valves to isolate the machine from the hydraulic system during servicing.
3. Manual or automatic air bleeding device at the system's highest point. Drainage device at the system's lowest point. Both the evaporator and the heat recovery device must not be positioned at the system's highest point.
4. A device that can maintain the hydraulic system under pressure (expansion tank, etc.)
5. Water temperature and pressure indicators on the machine to aid servicing and maintenance operations.
6. A filter or device that can remove extraneous particles from the water before it enters the pump (Please consult the pump manufacturer's recommendations for an appropriate filter to prevent cavitation). Use of a filter prolongs the life of the pump and helps keep the hydraulic system in best condition.
7. Another filter must be installed on the pipe conveying ingoing water to the machine, near the evaporator and heat recovery (if installed). The filter avoids solid particles entering the heat exchanger, as they could damage it or reduce its heat exchanging capacity.
8. The shell and tube heat exchanger has an electrical resistance with a thermostat that ensures protection against water freezing up to an outdoor temperature of -25°C . All the other hydraulic piping outside the machine must therefore be protected against freezing.
9. The heat recovery device must be emptied of water during the winter season, unless an ethylene glycol mixture in appropriate percentage is added to the water circuit.
10. If the machine is installed in order to replace another, the entire hydraulic system must be emptied and cleaned before the new unit is installed. Regular tests and proper chemical treatment of water are recommended before starting up the new machine.
11. In the event that glycol is added to the hydraulic system as anti-freeze protection, pay attention to the fact that intake pressure will be lower, the machine's performance will be lower and water pressure drops will be greater. All machine-protection methods, such as anti-freeze, and low-pressure protection will need to be reset. Before insulating water piping, check that there are no leaks.

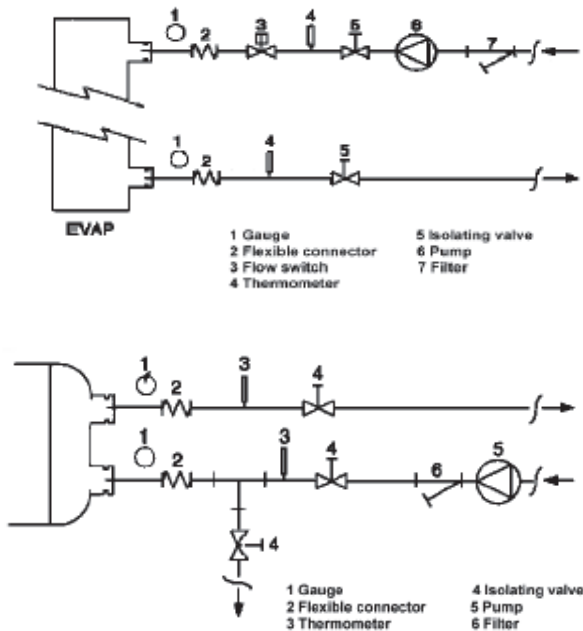

Hydraulic connection to heat exchangers

⚠ WARNING

Install a mechanical filter at the entrance of each heat exchanger. Failure to install the filter mechanic allows access of solid particles and / or welding slag inside the heat exchanger. We recommend the installation of a filter having a filtering net with holes not exceeding 0.5 mm in diameter. The manufacturer can not be held responsible for any damage to heat exchangers, due to the lack of the filter mechanical.

2.13 Water treatment

Before putting the machine into operation, clean the hydraulic circuit. Dirt, scales, corrosion residue and other extraneous material can accumulate inside the heat exchanger and reduce its heat exchanging capacity. Pressure drops can increase, as well, thus reducing water flow. Proper water treatment therefore reduces the risk of corrosion, erosion, scaling, etc. The most appropriate water treatment must be determined locally, according to the type of system and to the local characteristics of the process water.

Trane is not responsible for damage to or malfunctioning of equipment caused by failure to treat water or by improperly treated water.

Table - Acceptable water quality limits

PH (25°C)	6,8-8,0	Total Hardness (mg CaCO ₃ / l)	< 200
Electrical conductivity S/cm (25°C)	< 800	Iron (mg Fe / l)	< 1.0
Chloride ion (mg Cl - / l)	< 200	Sulfur ion (mg S ₂ - / l)	None
Sulphate ion (mg SO ₂₄ / l)	< 200	Ammonium ion (mg NH ₄₊ / l)	< 1.0
Alkalinity (mg CaCO ₃ / l)	< 100	Silica (mg SiO ₂ / l)	< 50

2.14 Antifreeze protection on the heat exchangers

Evaporator and recovery exchangers anti-freeze protection

All evaporators are supplied with a thermostatically controlled anti-freeze electrical resistance, which provides adequate anti-freeze protection up to -25°C. However, this method is not the only protection system against freezing, unless the heat exchangers are completely emptied and cleaned with anti-freeze solution.

Two or more protection methods should be foreseen when designing the system as whole:

1. Continuous water flow circulation inside piping and exchangers.
2. Addition of an appropriate amount of glycol inside the water circuit.
3. Additional heat insulation and heating of exposed piping.
4. Emptying and cleaning of the heat exchanger during the winter season

It is the responsibility of the installer and/or of local maintenance personnel to ensure two or more of the described antifreeze methods. Continuously verify, through routine checks, that appropriate anti-freeze protection is maintained. Failure to follow the instructions above could result in damage to some of the machine's components. Damage from freezing is not covered by the warranty.

2.15 Flow switch installation

To ensure adequate water flow through the evaporator, it is essential to install a flow switch on the water circuit. The flow may be either installed on both the inlet pipe of the water on that output. The purpose of the flow switch is to stop the machine in case of occurring an interruption of the water flow while protecting the evaporator from freezing. If the machine is equipped with total heat recovery, install another flow to ensure the flow of water before it is modified machine operation in heating mode (Heat Recovery Mode). The flow on recovery circuit prevents shutting down the machine for high pressure.

The flow switch can be mounted in any position far from elbows or bottlenecks and with the arrow in the direction of flow. For installations on vertical piping is necessary to calibrate the device to compensate for the weight of the headstock. If the unit is mounted to the bottom, we must make WARNING deposits that can form. The appliance must be installed in a straight pipe with no filters, valves, etc..., Have at least 5 times its diameter, both upstream and downstream

A flow meter specially selected for this purpose, is offered optionally. This flow switch, the blade type, is suitable for applications in harsh environments and suitable for pipes with diameters from 1 "to 8". The flow switch is provided with a contact which must be wired to terminals 11B and 12 (evaporator) of the terminal X (check the wiring diagram of the car for more information). For more information on the positioning and settings of the device, read the instruction sheet specific place inside the box of the device.

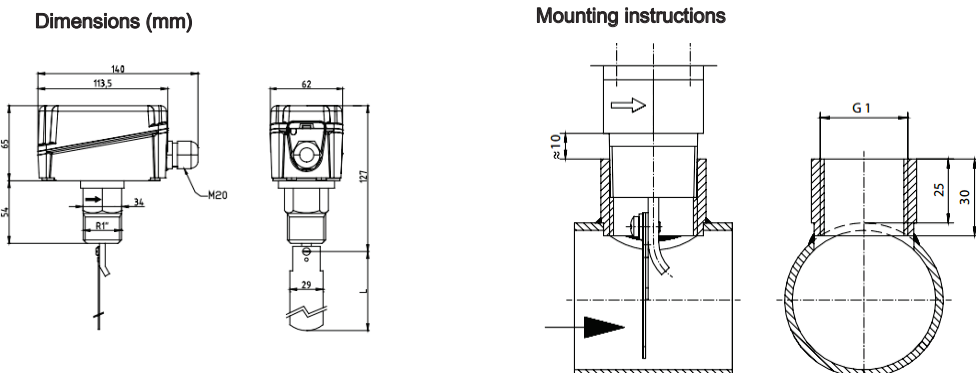

Paddle (model without "T" piece)

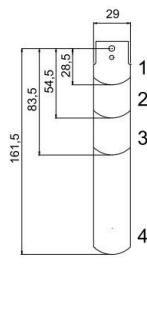

Tube dia.	Paddle
1"	1
1 1/4"	1
1 1/2"	1
2"	1,2
2 1/2"	1,2
3"	1,2,3
4"	1,2,3
4" Z	1,2,3,4
5"	1,2,3
5" Z	1,2,3,4
6"	1,2,3
6" Z	1,2,3,4
8"	1,2,3
8" Z	1,2,3,4

Electrical connection

Connect to the contact to the white and red of the microswitch (fig. 1). The red-white contact opens when the flow drops below the set value. In the absence of flow the contact red-blue closes and can be used as a contact signal or alarm.

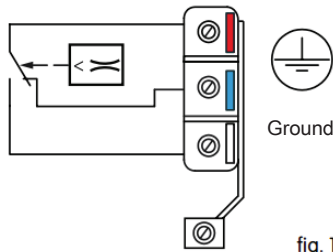

Screw for load control

Note

The flow switch is factory calibrated with reference to the minimum cut-out value. To increase this value, turn the adjustment screw clockwise. The cut-out value must be \geq the minimum flow necessary to ensure the protection of the system. The units without fittings will be supplied with 4 paddles (see drawing palette), which must be cut according to the pipe. On request they can be supplied to all devices with the T-piece

WARNING

In case the unit is used as a minimum flow controller must be placed downstream of a further control device for the activation of the alarm condition.

Installing the filter

To ensure proper operation of the heat exchanger, it is mandatory to install a filter on the input of the evaporator near the unit (max 2 meters). The component is required and must be mounted before making circular adequate flow of water through

2.16 Hydraulic data

WATER FLOW AND PRESSURE DROP

RTMA	plant side cold heat exchanger				plant side hot heat exchanger			
	V	K	Q min	Q max	V	K	Q min	Q max
	[m ³]		[m ³ /h]	[m ³ /h]	[m ³]		[m ³ /h]	[m ³ /h]
105	3,8	17,1	39,6	105,7	11,9	17,1	44,3	118,0
115	4,2	10,1	43,8	116,9	13,4	10,1	49,9	133,0
120	4,4	9,6	45,8	122,1	13,9	9,6	52,0	138,8
130	4,7	9,0	49,8	132,9	15,2	9,0	56,7	151,2
150	5,4	8,2	56,9	151,7	17,1	8,2	63,9	170,3
170	6,1	7,8	63,9	170,3	19,4	7,8	72,6	193,7
180	6,4	7,6	67,3	179,5	20,1	7,6	75,2	200,5
190	6,8	3,0	71,6	191,0	20,6	3,0	77,2	205,9
210	7,5	2,9	78,8	210,1	23,3	2,9	87,3	232,7
105 LN	3,8	17,1	38,2	102,0	11,9	17,1	38,2	119,4
115 LN	4,2	10,1	42,5	113,3	13,4	10,1	42,5	134,5
120 LN	4,4	9,6	44,4	118,5	13,9	9,6	44,4	140,4
130 LN	4,7	9,0	48,3	128,9	15,2	9,0	48,3	152,8
150 LN	5,4	8,2	55,5	147,9	17,1	8,2	55,5	172,0
170 LN	6,1	7,8	62,3	166,1	19,4	7,8	62,3	195,6
180 LN	6,4	7,6	65,6	174,8	20,1	7,6	65,6	202,5
190 LN	6,8	3,0	69,9	186,3	20,6	3,0	69,9	207,9
210 LN	7,5	2,9	76,8	204,9	23,3	2,9	76,8	235,1
105 SL	3,8	17,1	39,2	104,7	11,9	17,1	39,2	120,3
115 SL	4,2	10,1	43,5	115,9	13,4	10,1	43,5	135,6
120 SL	4,4	9,6	45,4	121,1	13,9	9,6	45,4	141,4
130 SL	4,7	9,0	49,4	131,8	15,2	9,0	49,4	153,9
150 SL	5,4	8,2	56,5	150,7	17,1	8,2	56,5	173,1
170 SL	6,1	7,8	63,4	169,2	19,4	7,8	63,4	196,9
180 SL	6,4	7,6	66,8	178,2	20,1	7,6	66,8	203,8
190 SL	6,8	3,0	71,1	189,7	20,6	3,0	71,1	209,3
210 SL	7,5	2,9	78,3	208,7	23,3	2,9	78,3	236,6

V : recommended water content of the plant (cold side and hot side) with dT 5 ° C on the heat exchanger

Q min: minimum water flow to the heat exchanger

Q max: maximum water flow to the heat exchanger

$$dpw = K \cdot Q^2 / 1000$$

$$Q = 0,86 P / \Delta t$$

P: Heating/cooling capacity [kW]

Δt: ΔT at the heat exchanger (min = 3, max = 8) [°C]

dpw Pressure drop [kPa]

10.2 HYDRONIC GROUP

The units of the **RTMA** family are also available in multiple hydraulic versions, characterized by complete kits of all major hydraulic components for an easier installation, with reduced time, cost and space. The wide range of hydraulic versions available make the unit suitable for any type of installation.

HYDRAULIC VERSIONS

2 pumps low head pressure 150kPa

2 pumps medium head pressure 250kPa

2 pumps high head pressure 450kPa

2.17 Hydronic kit

Centrifugal pumps with 2 or 4 poles, axial suction bowls and radial delivery, available in low, medium or high head pressure.

Pumps with cast iron body and impeller entirely welded using laser technology. Mechanical seal with ceramic components, coal and EPDM elastomers. Three phase electric motor with IP55 protection and insulation class F, suitable for continuous service.

Series motors with higher efficiency IE2 technology.

- Differential pressure switch on exchanger
- Discharge taps
- Taps on pumps suction / delivery which allow the replacement of a damaged pump eliminating the plant shutdown differently from other types of common use.
- Check valve
- Relief valve
- Discharge valve
- Minimum pressure switch for automatic changeover of the pumps.

The stand by pump accessory is also available , including 2 additional pumps(one for the cold circuit and the other for the hot circuit) in stand-by mode to the first, equipped with the automatic changeover including also the pressure switch for the intervention of the second pump. The pumps operate with the balance of the related working hours. In case of failure of one pump the controller in automatic switches on the additional pump. The control panel is equipped with fuses and contactor with thermal protection.

HYDRONIC ACCESORIES ON REQUEST

- "Y" water strainer (sold separately), consists of body and stainless steel mesh, with replaceable filter through the inspection cap.
- Automatic water filling (sold separately).
- Stand by pump for air conditionin circuit + stand by pump for heating circuit ,150 kPa
- Stand by pump for air conditionin circuit + stand by pump for heating circuit ,250 kPa
- Stand by pump for air conditionin circuit + stand by pump for heating circuit ,450 kPa

LOW HEAD PRESSURE PUMP (150kPa)

COOLING MODE

RTMA 105 - 210

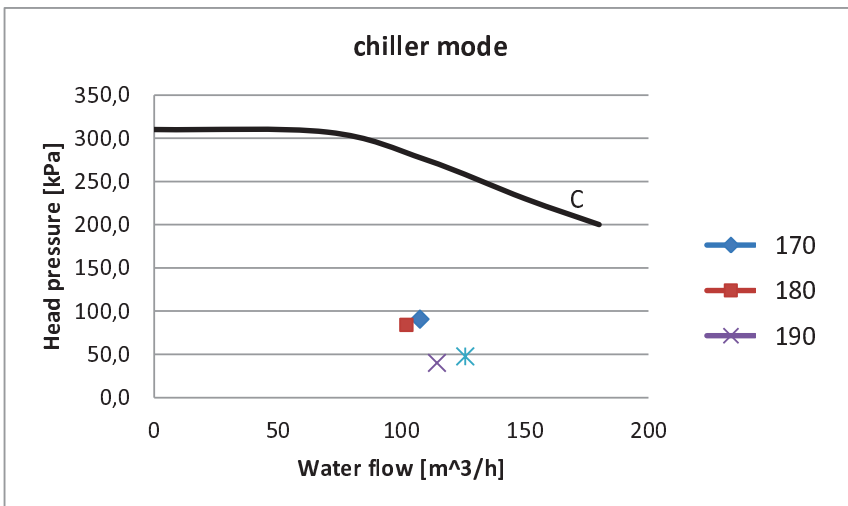
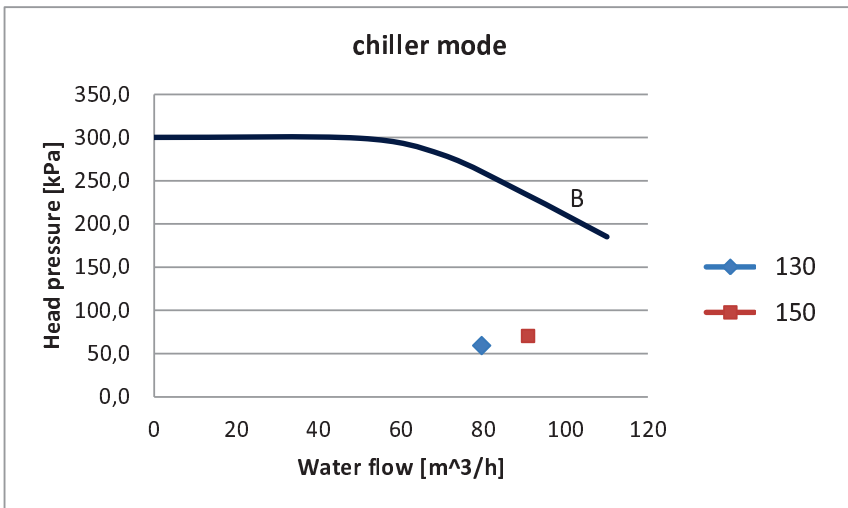
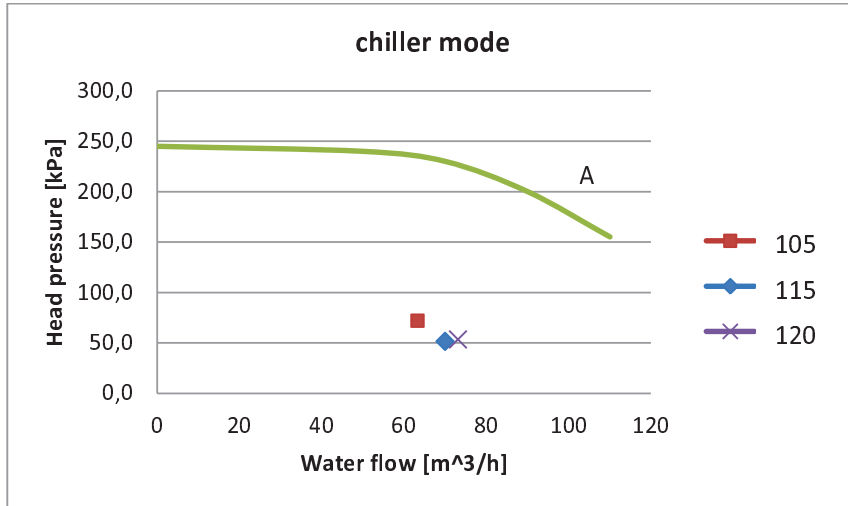

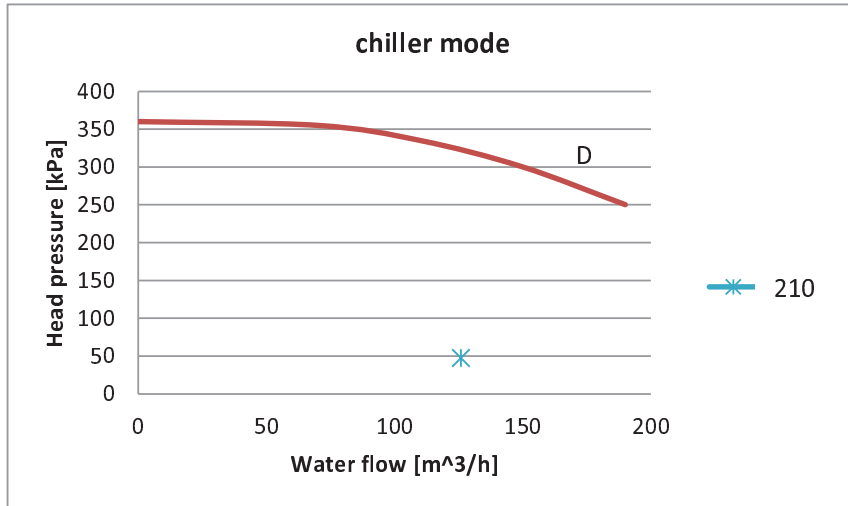

Mod.	Pf	qw	dpw	Ref. curve	Expansion vessel [l]	F.L.I.	F.L.A.	Hp	Hu
	kW	m ³ /h	kPa			kW	A	kPa	kPa
105	368,70	63,3	72	A	2x24	7,5	14,2	237,2	165,2
115	407,70	70,0	51	A	2x24	7,5	14,2	232,8	181,4
120	426,00	73,1	53	A	2x24	7,5	14,2	230,3	176,9
130	463,50	79,5	59	B	2x24	9	16,5	259,9	200,6
150	529,20	90,8	70	B	2x24	9	16,5	236,0	165,6
170	594,20	102,0	84	C	2x24	15	25,8	282,9	198,7
180	626,20	107,4	91	C	2x24	15	25,8	278,6	187,8
190	666,30	114,3	40	C	2x24	15	25,8	272,9	232,7
210	733,00	125,8	48	D	2x24	18,5	32,9	262,4	214,6

Pf Cooling capacity (kW)

qw Water flow (m³/h)

dpw Pressure drop (kPa)

F.L.I. Full load electrical power input

F.L.A. Full load operating current

Hp Pump Head pressure

Hu Available head pressure

HEATING MODE

RTMA 105- 210

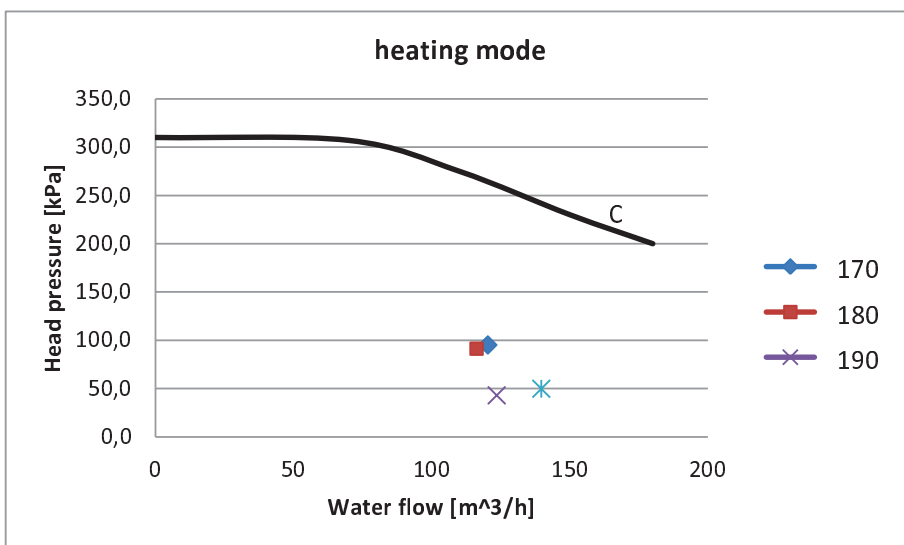
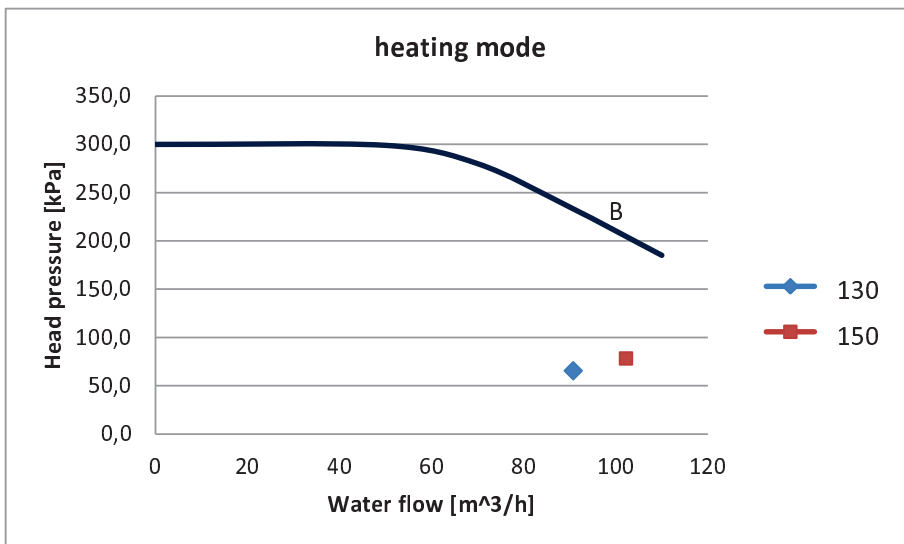
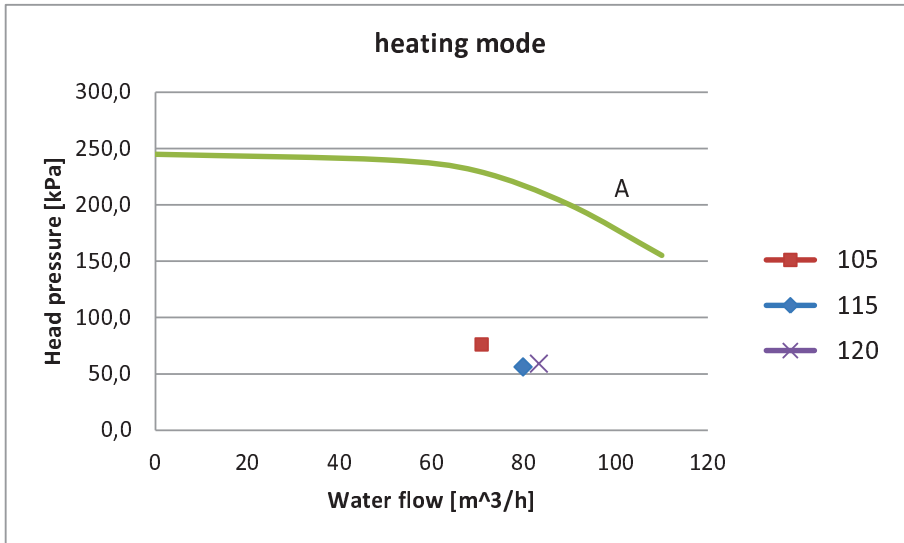

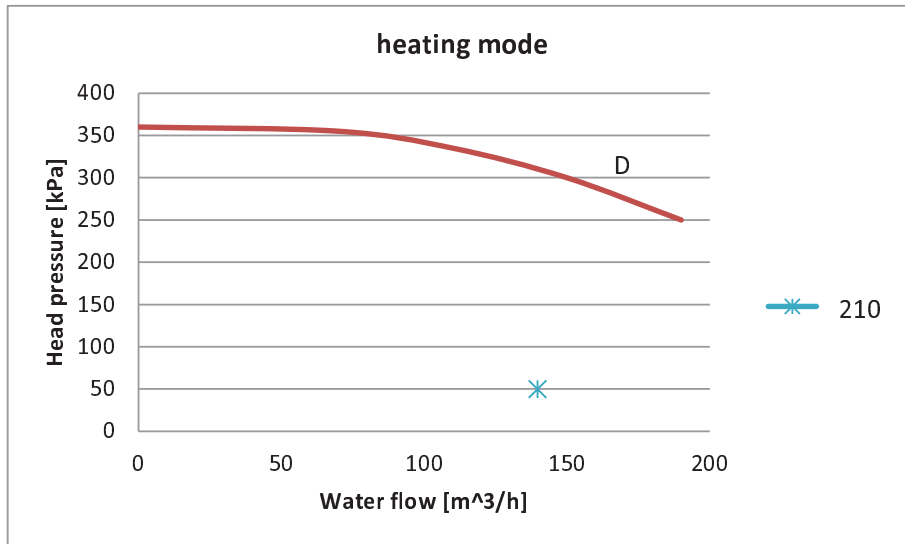

Mod.	Pt	qw	dpw	Ref. curve	Expansion vessel	F.L.I.	F.L.A.	Hp	Hu
	kW	m ³ /h	kPa						
105	411,80	70,8	76	A	2x24	7,5	14,2	237,2	165,2
115	464,10	79,8	56	A	2x24	7,5	14,2	232,8	181,4
120	484,10	83,3	59	A	2x24	7,5	14,2	230,3	176,9
130	527,50	90,7	65	B	2x24	9	16,5	259,9	200,6
150	594,10	102,2	78	B	2x24	9	16,5	236,0	165,6
170	675,70	116,2	91	C	2x24	15	25,8	282,9	198,7
180	699,40	120,3	95	C	2x24	15	25,8	278,6	187,8
190	718,10	123,5	43	C	2x24	15	25,8	272,9	232,7
210	811,90	139,6	50	D	2x24	18,5	32,9	262,4	214,6

Pt Heating capacity (kW)

qw Water flow (m³/h)

dpw Pressure drop (kPa)

F.L.I. Full load electrical power input

F.L.A. Full load operating current

Hp Pump Head pressure

Hu Available head pressure

MEDIUM HEAD PRESSURE PUMP (250kPa)

COOLING MODE

RTMA 105 - 210

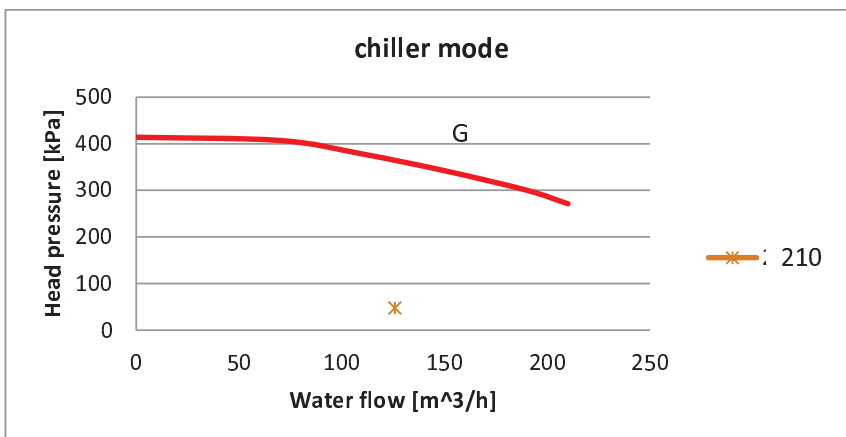
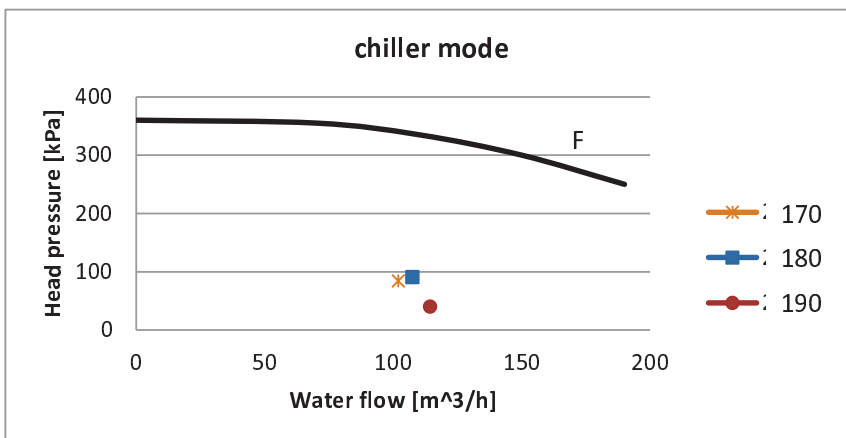
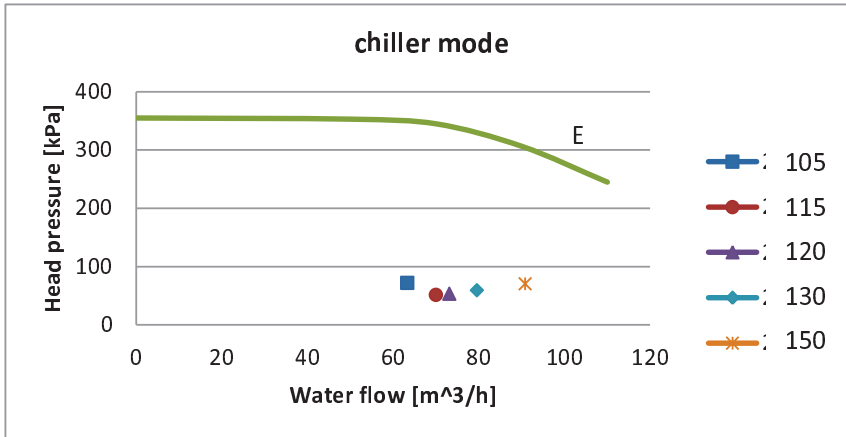

Mod.	Pf	qw	dpw	Ref. curve	Expansion vessel	F.L.I.	F.L.A.	Hp	Hu
	kW	m ³ /h	kPa		[l]	kW	A	kPa	kPa
105	368,70	63,3	72	E	2x24	11	19,3	348,2	276,2
115	407,70	70,0	51	E	2x24	11	19,3	342,2	290,8
120	426,00	73,1	53	E	2x24	11	19,3	338,7	285,3
130	463,50	79,5	59	E	2x24	11	19,3	329,6	270,3
150	529,20	90,8	70	E	2x24	11	19,3	307,0	236,5
170	594,20	102,0	84	F	2x24	18,5	32,9	340,3	256,1
180	626,20	107,4	91	F	2x24	18,5	32,9	336,8	246,0
190	666,30	114,3	40	F	2x24	18,5	32,9	332,1	291,9
210	733,00	125,8	48	G	2x24	22	39	366,8	319,1

Pf Cooling capacity (kW)

qw Water flow (m³/h)

dpw Pressure drop (kPa)

F.L.I. Full load electrical power input

F.L.A. Full load operating current

Hp Pump Head pressure

Hu Available head pressure

HEATING MODE

RTMA 105 -210

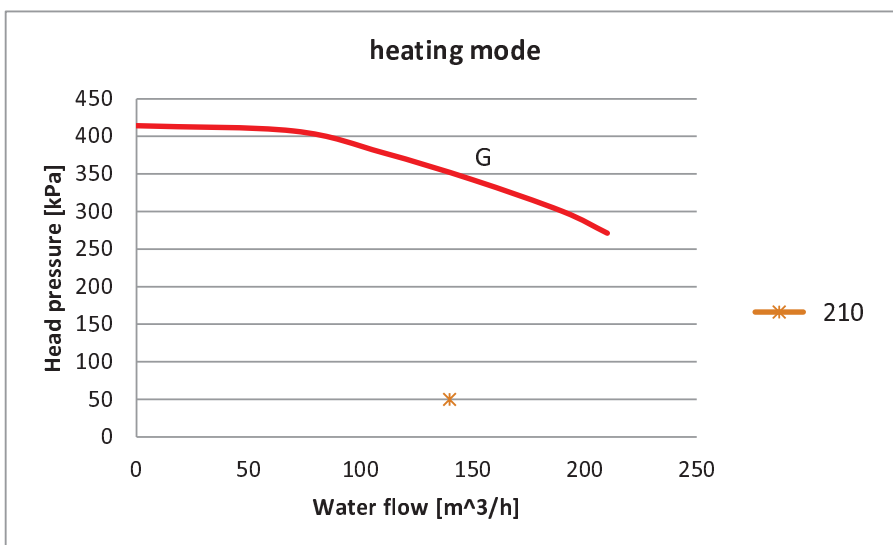
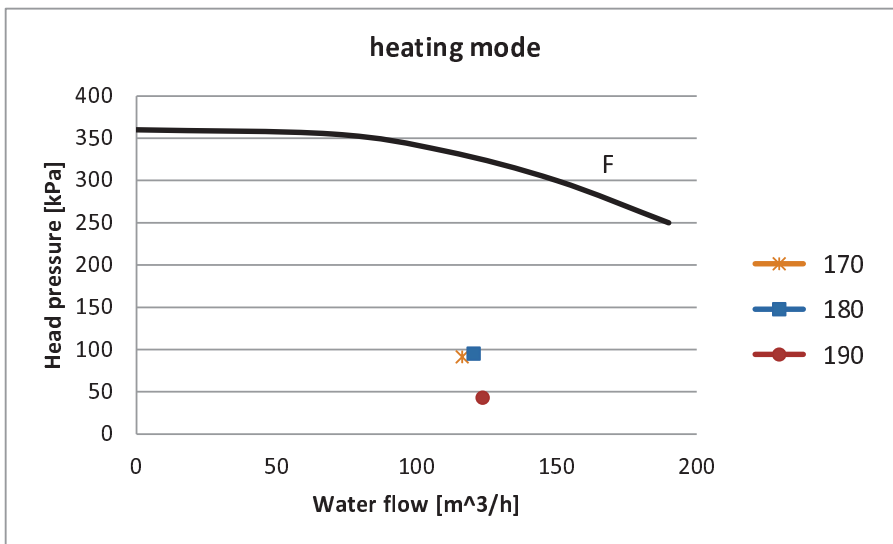
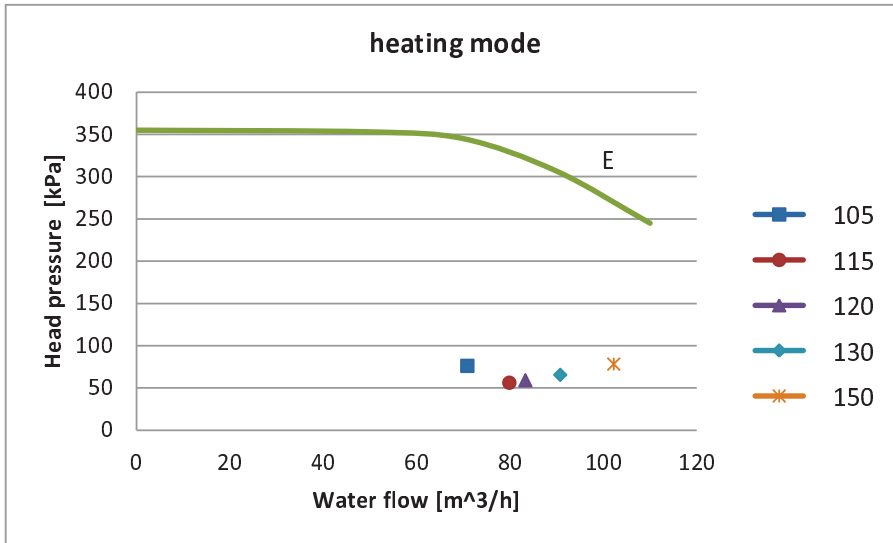

INSTALLATION OPERATION MAINTENANCE

Mod.	Pf	qw	dpw	Ref. curve	Expansion vessel [l]	F.L.I.	F.L.A.	Hp	Hu
	kW	m ³ /h	kPa			kW	A	kPa	kPa
105	411,80	70,8	76	E	2x24	7,5	14,2	341,3	265,3
115	464,10	79,8	56	E	2x24	7,5	14,2	329,1	273,0
120	484,10	83,3	59	E	2x24	7,5	14,2	323,1	264,1
130	527,50	90,7	65	E	2x24	9	16,5	307,1	241,7
150	594,10	102,2	78	E	2x24	9	16,5	274,1	196,0
170	675,70	116,2	91	F	2x24	15	25,8	330,8	239,6
180	699,40	120,3	95	F	2x24	15	25,8	327,7	232,7
190	718,10	123,5	43	F	2x24	15	25,8	325,2	282,4
210	811,90	139,6	50	G	2x24	18,5	32,9	354,3	304,6

Pt Heating capacity (kW)

qw Water flow (m³/h)

dpw Pressure drop (kPa)

F.L.I. Full load electrical power input

F.L.A. Full load operating current

Hp Pump Head pressure

Hu Available head pressure

HIGH HEAD PRESSURE PUMP (450kPa)

COOLING MODE

RTMA 150 - 210

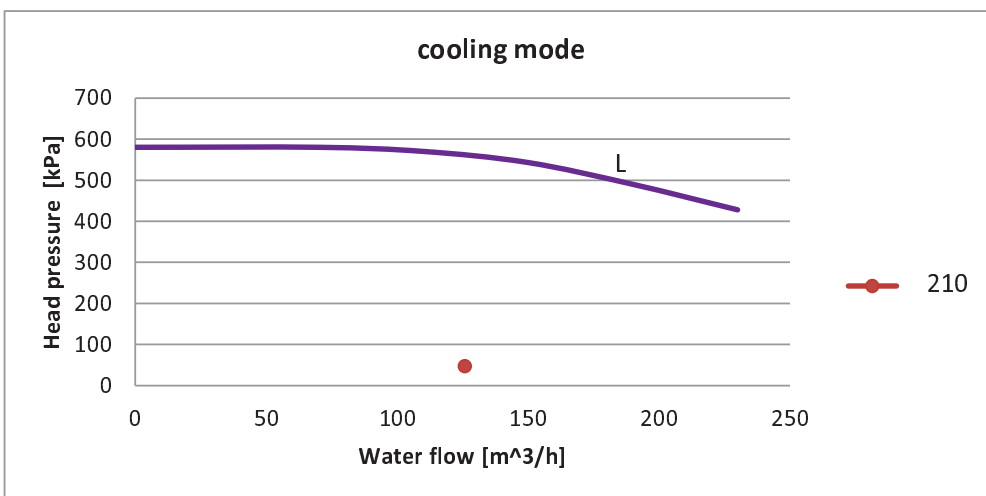
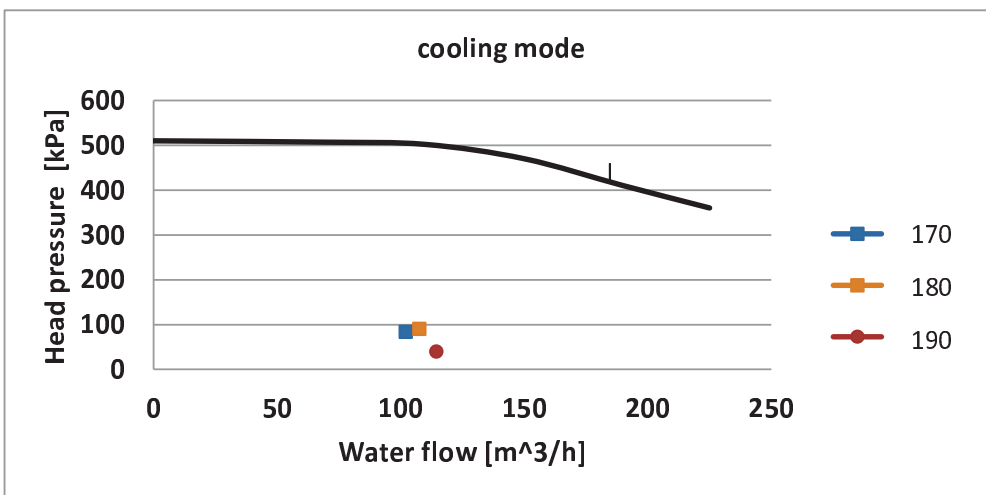
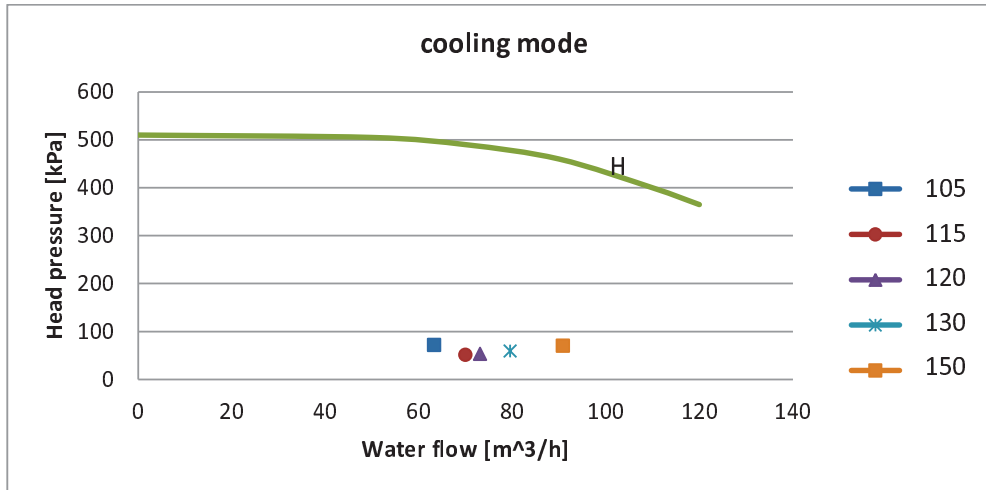

Mod.	Pf	qw	dpw	Ref. curve	Expansion vessel [l]	F.L.I.	F.L.A.	Hp	Hu
	kW	m ³ /h	kPa			kW	A	kPa	kPa
105	368,70	63,3	72	H	2x24	11	18,5	32,9	433,8
115	407,70	70,0	51	H	2x24	11	18,5	32,9	450,8
120	426,00	73,1	53	H	2x24	11	18,5	32,9	446,8
130	463,50	79,5	59	H	2x24	11	18,5	32,9	435,8
150	529,20	90,8	70	H	2x24	11	18,5	32,9	412,2
170	594,20	102,0	84	I	2x24	18,5	30	54,0	417,6
180	626,20	107,4	91	I	2x24	18,5	30	54,0	408,2
190	666,30	114,3	40	I	2x24	18,5	30	54,0	455,0
210	733,00	125,8	48	L	2x24	22	37	63,0	511,5

Pf Cooling capacity (kW)

Pt Heating capacity (kW)

qw Water flow (m³/h)

dpw Pressure drop (kPa)

F.L.I. Full load electrical power input

F.L.A. Full load operating current

Hp Pump Head pressure

Hu Available head pressure

HEATING MODE

RTMA 105 – 210

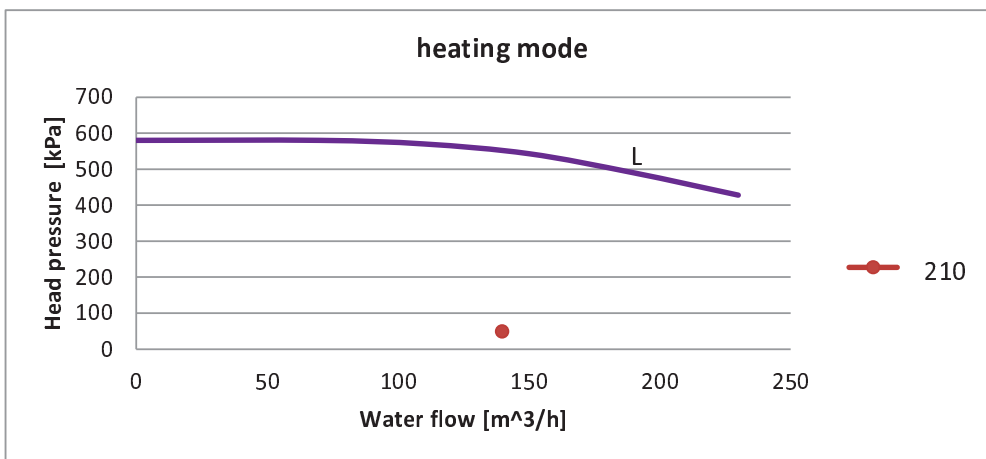
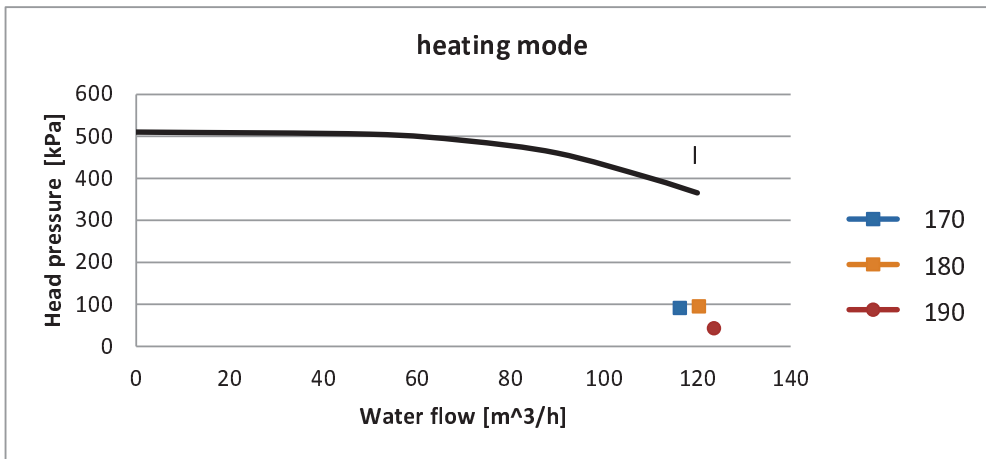
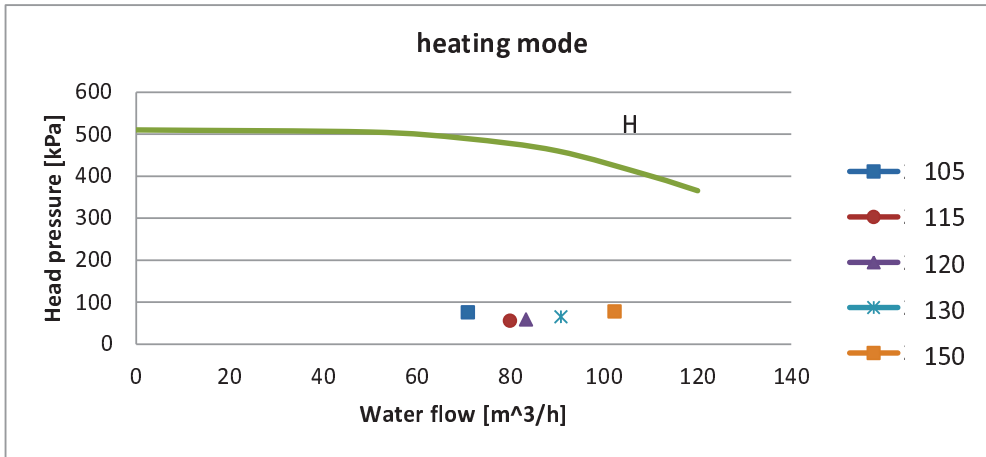

INSTALLATION OPERATION MAINTENANCE

Mod.	Pt	qw	dpw	Ref. curve	Expansion vessel [l]	F.L.I.	F.L.A.	Hp	Hu
	kW	m ³ /h	kPa			kW	A	kPa	kPa
105	411,80	70,8	76	H	2x24	18,5	32,9	501,7	425,7
115	464,10	79,8	56	H	2x24	18,5	32,9	494,8	438,7
120	484,10	83,3	59	H	2x24	18,5	32,9	491,4	432,5
130	527,50	90,7	65	H	2x24	18,5	32,9	482,7	417,3
150	594,10	102,2	78	H	2x24	18,5	32,9	464,7	386,6
170	675,70	116,2	91	I	2x24	30	54	494,1	402,9
180	699,40	120,3	95	I	2x24	30	54	491,5	396,5
190	718,10	123,5	43	I	2x24	30	54	489,4	446,5
210	811,90	139,6	50	L	2x24	37	63	548,0	498,4

Pt Heating capacity (kW)

qw Water flow (m³/h)

dpw Pressure drop (kPa)

F.L.I. Full load electrical power input

F.L.A. Full load operating current

Hp Pump Head pressure

Hu Available head pressure

CONNECTION SCHEME - STANDARD VERSION

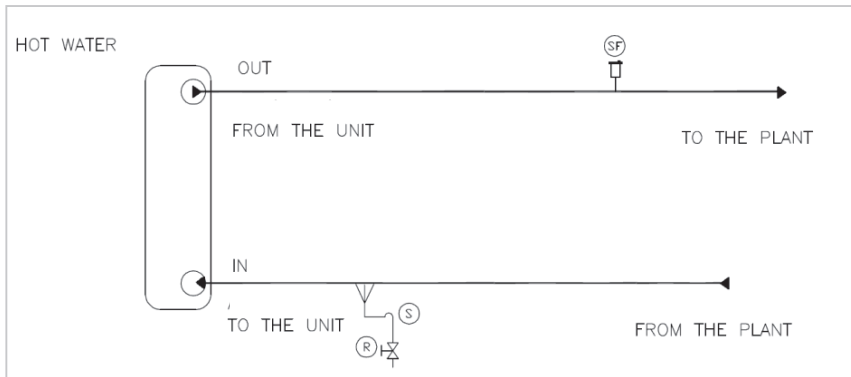
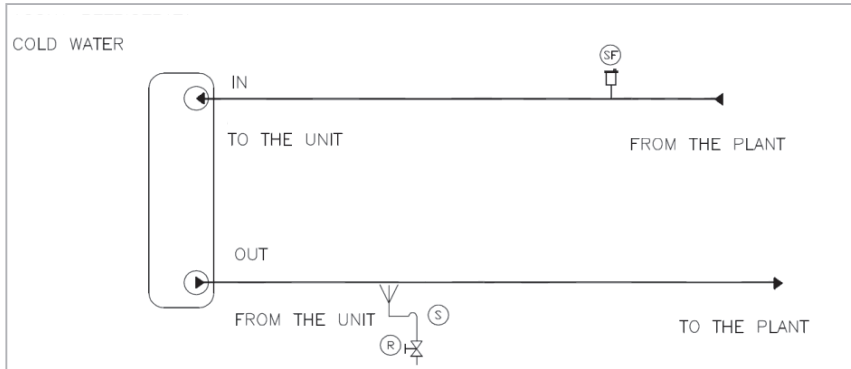

- S Water discharge
- SF Relief valve
- R Shut off valve

INSTALLATION OPERATION MAINTENANCE

HYDRONIC KIT WITH 1 PUMP HOT SIDE + 1 PUMP COLD SIDE

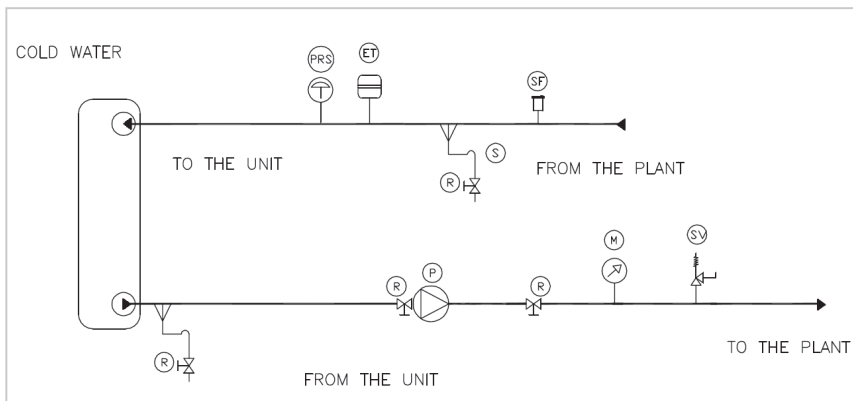
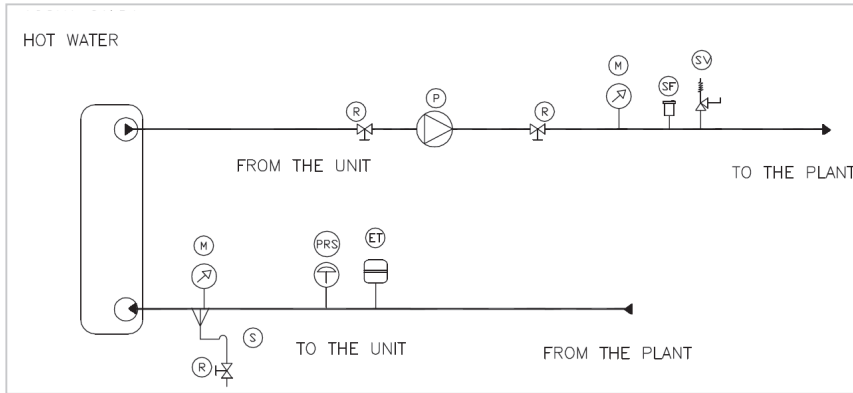

- M Gauges
- S Water discharge
- P Pump
- SV Safety valve
- SF Relief valve
- ET Expansion vessel
- PRS Empty plant security pressure switch
- R Shut off valve

HYDRONIC KIT WITH 2 PUMP HOT SIDE + 2 PUMP COLD SIDE

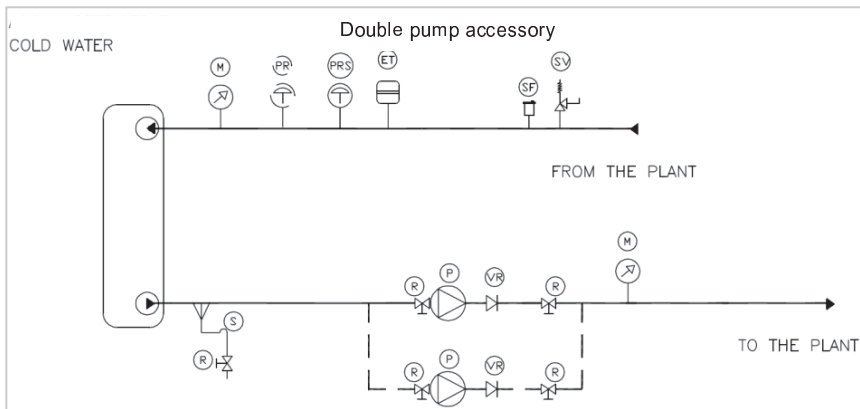
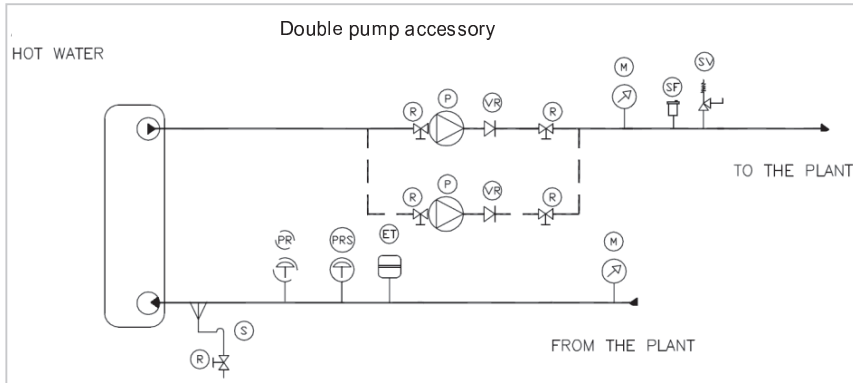

- M Gauges
- S Water discharge
- P Pump
- SV Safety valve
- SF Relief valve
- ET Expansion vessel
- PD Water differential pressure switch
- PRS Empty plant security pressure switch
- R Shut off valve
- PR Additional pump water pressure switch
- VR Check valve

2.18 Refrigerating circuit safety valves

Each system comes with safety valves that are installed on each circuit, both on the evaporator and on the condenser. The purpose of the valves is to discharge the refrigerant inside the refrigerating circuit in the event of any malfunction.

WARNING

This unit is designed for installation outdoors. However, check that there is sufficient air circulation around the machine. If the machine is installed in closed or partly covered areas, possible damage from inhalation of refrigerant gases must be avoided. Avoid releasing the refrigerant in the environment.

The safety valves must be connected externally. The installer is responsible for connecting the safety valves to the discharge piping and for establishing their size.

2.19 Heat exchanger pressure drop

It is possible to use machines with different flow rates from the nominal ones and consequently with different temperature differences from nominal. It is not recommended to machine with thermal jumps too high, since very low water flow may cause coil freezing with automatic exclusion of warranty, or vice versa, too low, since very high water flow rates result in excessive water velocity and possible erosion / corrosion. In the first case low speed 'can lead to underperformance and easy scaling, and in the second case' must install pumps with high prevalence energetically little valid.

2.20 Control and safety calibration

SCALING CORRECTION SCHEDULES

The following table provides information on the organs of action and safety of the unit '. Always verify that the unit 'is within the limits imposed by pressure switches or pressure transducers and periodically check the calibration.

	UM	open	close	value
High pressure switch	barg	17	12	-
Low pressure switch	barg	0,35	1,2	-
Safety valve	barg	-	-	24,5
Antifreeze protection	°C			4
N° start compressor max per hour	N			10

U.M = measurement unit

ETHYLENE GLYCOL CORRECTION SCHEDULE

% Ethylene glycol weight		5%	10%	15%	20%	25%	30%	35%	40%
Freezing temperature	°C	-2	-3,9	-6,5	-8,9	-11,8	-15,6	-19	-23,4
Suggested security limit	°C	3	1	-1	-4	-6	-10	-14	-19
Cooling capacity coefficient	-	0,995	0,99	0,985	0,981	0,977	0,974	0,971	0,968
Power input coefficient	-	0,997	0,993	0,99	0,988	0,986	0,984	0,982	0,981
Flow rate coefficient	-	1,003	1,01	1,02	1,033	1,05	1,072	1,095	1,124
Pressure drop coefficient	-	1,029	1,06	1,09	1,118	1,149	1,182	1,211	1,243

In order to calculate performance with glycol solutions multiply main sizes by respective coefficients.

GLICOLE PERCENTAGE DEPENDING ON FREEZING TEMPERATURE

% glycol according to the freezing temperature							
Freezing temperature	0°C	-5°C	-10°C	-15°C	-20°C	-25°C	
% Ethylene glycol	5%	12%	20%	28%	35%	40%	
Flow rate coefficient	1,02	1,033	1,05	1,072	1,095	1,124	

In order to calculate performance with glycol solutions multiply main sizes by respective coefficients.

FOULING FACTOR CORRECTION TABLE

Fouling Factor	Plant side cold heat exchanger			Plant side hot heat exchanger		
	A1	B1	Tmin	A2	B2	Tmax
F.F.						
[m ² °C*W]						
0	1,00	1,00	0,00	1,00	1,00	0,00
1,80E-05	1,00	1,00	0,00	1,00	1,00	0,00
4,40E-05	1,00	1,00	0,00	0,99	1,03	1,00
8,80E-05	0,96	0,99	0,70	0,98	1,04	1,50
1,32E-04	0,94	0,99	1,00	0,96	1,05	2,30
1,72E-04	0,93	0,98	1,50	0,95	1,06	3,00

A factor

B factor

Tmin

T max

Capacity correction factor

Compressor power input correction factor

Minimum evaporator outlet water temperature increase

Maximum condenser outlet water temperature decrease

3 Electrical installation

General specification

WARNING

All electrical connections to the machine must be carried out in compliance with laws and regulations in force. All installation, management and maintenance activities must be carried out by qualified personnel. Refer to the specific wiring diagram for the machine that you have purchased and which was sent with the unit. Should the wiring diagram not appear on the machine or should it have been lost, please contact your nearest Trane office, who will send you a copy

WARNING

Only use copper conductors. Failure to use copper conductors could result in overheating or corrosion at connection points and could damage the unit. To avoid interference, all control wires must be connected separately from the power cables. Use different electrical passage ducts for this purpose.

WARNING

Before servicing the machine in any way, open the general disconnecting switch on the machine's main power supply. When the machine is off but the disconnecting switch is in the closed position, unused circuits are live, as well. Never open the terminal board box of the compressors before having opened the unit's general disconnecting switch.

WARNING

The units are equipped with electrical components non-linear high power (VFD power of the compressors, such as I, introduces higher order harmonics can cause a significant leakage ground (of the order of 2 A)

The protectors of the power supply system must take into account the value of the above mentioned.

3.1 Electric data

RTMA

NOMINAL VALUES									MAX VALUES (1)		
Outdoor air temperature 35 ° C, evaporator water temperature in / out 12/7 ° C											
Mod.	Compressors (2)		Fans			TOTAL			TOTAL		
	F.L.I.	F.L.A.	L.R.A	E.P.	O.C.	F.L.I.	F.L.A.	S.A.	F.L.I.	F.L.A.	S.A.
	kW	A	A	kW	A	kW	A	A	kW	A	A
105	113,5	192,9	373,0	12,0	24,0	125,5	216,9	493,5	184,7	314,0	542,0
115	127,2	216,2	405,0	12,0	24,0	139,2	240,2	537,1	202,4	344,0	574,0
120	131,0	225,9	488,0	15,0	30,0	147,9	255,9	631,0	188,2	320,0	678,0
130	137,1	233,1	488,0	15,0	30,0	152,1	263,1	634,5	194,1	330,0	678,0
150	156,1	265,4	434,0	18,0	36,0	174,1	301,4	602,7	232,9	396,0	650,0
170	168,8	287,0	530,0	18,0	36,0	186,8	323,0	709,5	254,1	432,0	764,0
180	182,4	310,1	587,0	18,0	36,0	200,4	346,1	778,0	267,6	455,0	844,0
190	193,4	328,8	587,0	21,0	42,0	214,4	370,8	793,4	284,7	484,0	850,0
210	214,0	363,8	587,0	21,0	42,0	235,0	405,8	810,9	321,2	546,0	912,0

RTMA LN

NOMINAL VALUES									MAX VALUES (1)		
Outdoor air temperature 35 ° C, evaporator water temperature in / out 12/7 ° C											
Mod.	Compressors (2)		Fans			TOTAL			TOTAL		
	F.L.I.	F.L.A.	L.R.A	E.P.	O.C.	F.L.I.	F.L.A.	S.A.	F.L.I.	F.L.A.	S.A.
	kW	A	A	kW	A	kW	A	A	kW	A	A
105	113,5	192,9	373,0	12,0	24,0	125,5	216,9	493,5	184,7	314,0	542,0
115	127,2	216,2	405,0	12,0	24,0	139,2	240,2	537,1	202,4	344,0	574,0
120	132,9	225,9	488,0	15,0	30,0	147,9	255,9	631,0	188,2	320,0	678,0
130	137,1	233,1	488,0	15,0	30,0	152,1	263,1	634,5	194,1	330,0	678,0
150	156,1	265,4	434,0	18,0	36,0	174,1	301,4	602,7	232,9	396,0	650,0
170	168,8	287,0	530,0	18,0	36,0	186,8	323,0	709,5	254,1	432,0	764,0
180	182,4	310,1	587,0	18,0	36,0	200,4	346,1	778,0	267,6	455,0	844,0
190	193,4	328,8	587,0	21,0	42,0	214,4	370,8	793,4	284,7	484,0	850,0
210	214,0	363,8	587,0	21,0	42,0	235,0	405,8	810,9	321,2	546,0	912,0

RTMA SL

INSTALLATION OPERATION MAINTENANCE

NOMINAL VALUES									MAX VALUES (1)		
Outdoor air temperature 35 ° C, evaporator water temperature in / out 12/7°C											
Mod.	Compressors (2)		Fans			TOTAL			TOTAL		
	F.L.I.	F.L.A.	L.R.A	E.P.	O.C.	F.L.I.	F.L.A.	S.A.	F.L.I.	F.L.A.	S.A.
	kW	A	A	kW	A	kW	A	A	kW	A	A
105	114,4	194,6	373,0	8,4	16,8	125,5	216,9	493,5	180,5	306,8	534,8
115	128,2	217,9	405,0	8,4	16,8	139,2	240,2	537,1	198,1	336,8	566,8
120	124,8	212,1	488,0	10,5	21,0	147,9	255,9	631,0	182,9	311,0	669,0
130	138,3	235,1	488,0	10,5	21,0	152,1	263,1	634,5	188,8	321,0	669,0
150	157,5	267,7	434,0	12,6	25,2	174,1	301,4	602,7	226,6	385,2	639,2
170	170,3	289,5	530,0	12,6	25,2	186,8	323,0	709,5	247,8	421,2	753,2
180	184,0	312,8	587,0	12,6	25,2	200,4	346,1	778,0	261,3	444,2	833,2
190	195,1	331,6	587,0	14,7	29,4	214,4	370,8	793,4	277,3	471,4	837,4
210	215,9	367,0	587,0	14,7	29,4	235,0	405,8	810,9	313,8	533,4	899,4

Electrical data referred to 400V - 3PH+N-50Hz

Maximum operating admitted conditions: 10%

Maximum phase unbalance: 3%

F.L.I. full load electrical power

F.L.A. full load operating current

L.R.A. compressor motor locked rotor current (direct starting)

S.A. sum of LRA of the most powerful compressor, FLA of other compressor and fans current

E.P. electrical power

O.C. operating current

(1) maximum operating admitted conditions by the compressors manufacturer

(2) data referred to the biggest compressor for units with different compressors

3.2 Electrical components

All power and interface electrical connections are specified in the wiring diagram that is shipped with the machine. The installer must supply the following components:

- Power supply cables (dedicated duct)
- Interconnection and interface cables (dedicated duct)
- Thermal-magnetic circuit breaker of suitable size (please see electrical data).

3.3 Electrical connections

Power circuit:

Connect the power supply wires directly to the terminals of the overall place in the framework of the machine. The access panel must be drilled depending on the section of the cable used and its gland. Can also be used a flexible pipe containing the three supply phases plus ground.

In every way to ensure total protection against the possible penetration of water into the connection point.

Control circuit:

The control circuit is powered with 24V ddc. Each machine of the series is provided with auxiliary transformer control circuit 230/24V. It is not therefore requires no additional power cable to the control equipment.

Only in the case where it is required the separate optional storage tank is necessary to feed separately antifreeze heater.

Electric heaters

The machine has an antifreeze heater installed directly into the evaporator. each circuit also has an electric resistance installed in the compressor in order to keep warm the oil and thus avoid the transmigration of the refrigerant in its interior. Obviously the operation of the electrical resistors is guaranteed only if this constant power supply. If you can not leave the fed machine during the winter stop, apply at least two of the procedures described in the section "Installation - Mechanics" in "Frost protection of the evaporator and heat recovery exchangers."

Alarm Relay – Electrical connections

The unit is equipped with an alarm relay, which changes state every time an alarm occurs in one of the cooling circuits. Connect the terminals as per the wiring diagram on the machine - terminal "X" - a visual or audible alarm or any external supervision system.

BMS to monitor its operation. See the wiring of the machine for wiring.

Remote On / Off unit - Electrical connection

The machine has a digital input that allows remote control of the machine as per the wiring diagram on the machine - terminal "X" -. This input can be connected to a clock start-up, a switch or a BMS. Once closed, the microprocessor starts the boot sequence before turning on the water pump and then the compressors. On opening the contact, the microprocessor starts the shutdown sequence of the machine. The contact must be clean.

External reset of the setpoint of the water - Electrical connection (Optional)

The local setpoint of the machine can be varied via an external analog signal 4-20ma.

The signal cable should be connected directly to the terminal strip "X" as per the wiring diagram in broths machine. The signal cable should be shielded and not the type to be passed in the vicinity of the power cables to the electronic controller.

End user Electrical board connection - “X”



=QG		
X		
Customer Terminal Block		
NumM	NumI	Utenza
1	F	Remote ON/OFF
2	17	Remote ON/OFF
3	12	Evaporator flow switch FLE
4	13	Evaporator flow switch FLE
5	20	Alarm general relay free voltage - circuit 1 INOI
6	21	Alarm general relay free voltage - circuit 1 INOI
7	22	Alarm general relay free voltage - circuit 2 ICOMI
8	23	Alarm general relay free voltage - circuit 2 INOI
9	25	Alarm failure to initiate evaporator water pumps relay free voltage
10	27	Alarm failure to initiate evaporator water pumps relay free voltage
11	28	Alarm failure to initiate recovery water pumps relay free voltage
12	30	Alarm failure to initiate recovery water pumps relay free voltage
13	81	Free volt. contact for ext. water pump evaporator 1 status INOI
14	82	Free volt. contact for ext. water pump evaporator 1 status INOI
15	83	Free volt. contact for ext. water pump recovery 1 status INOI
16	84	Free volt. contact for ext. water pump recovery 1 status INOI
17	85	Free volt. contact for ext. water pump evaporator 2 status INOI
18	86	Free volt. contact for ext. water pump evaporator 2 status INOI
19	87	Free volt. contact for ext. water pump recovery 2 status INOI
20	88	Free volt. contact for ext. water pump recovery 2 status INOI
21	89	Request evaporator pump 1
22	90	Request evaporator pump 1
23	91	Request recovery pump 1
24	92	Request recovery pump 1
25	93	Request evaporator pump 2
26	94	Request evaporator pump 2
27	95	Request recovery pump 2
28	96	Request recovery pump 2
30	207	External activation set point lanalog signalI
29	210	External activation set point lanalog signalI

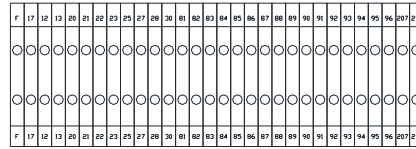

This scheme for reference only: please refer to electrical drawing in the unit

4 Unit working

4.1 Operator Responsibilities

It is important that the operator is properly trained and become familiar with the equipment before working on the machine. In addition to reading this manual, the operator must study the manual operation of the microprocessor and the wiring diagram to understand the sequence of start-up, operation, shutdown sequences, and the criterion of operation of all safety devices. During the initial start-up of the machine an authorized technician is available to answer any questions and educate on the proper functioning. We recommend the operator to maintain a record of the operating data for each machine installed. Moreover, another record should be maintained for all maintenance activities and periodic service. If the operator checks abnormal or unusual operating conditions, it is recommended to consult the Servizio authorized technician.

4.2 Unit description

The unit, of the type air cooled, consists of the following main components:

CASING

Made of galvanized and painted steel with increased thickness and with thermoset polyurethane powder, dried in the oven. The main components (compressor and refrigerant circuit components) are contained in a closed box enclosure with different possibilities of acoustic insulation allowing a more easy ordinary and extraordinary maintenance of the components. A closed compartment, easily inspectable, protecting exchangers and pumps is located in the condensing section of the unit. The whole structure is made of galvanized and painted steel. The assembled base frame is composed by longitudinal and transverse components with a thickness of 3mm, coupled by high resistance nailing, the profile has a base of 80mm suitable to the mounting of spring or rubber shock absorbers through holes of 18mm. The structure is fixed to the uprights (thickness 2mm) with bolts and threaded inserts to facilitate their removal, the particular profile of the uprights allow the installation of inspection panels and grids embedded type to protect all the components and at the same time to allow easy and immediate access during any maintenance and service operation.

The painting treatment of the casing is made with epoxy powder, which gives the whole structure a long lasting resistance for outdoor installation, even in aggressive environmental conditions.

COMPRESSORS

Semi-hermetic twin screw helical oil injection, complete with oil separator built in three stages, the latest generation, and oil filter, both for increased efficiency. The compressor is birotore lobe with male and female with very high precision workmanship.

The five-lobe rotor is directly mounted on the two pole motor without the interposition of gearboxes. The bearings disposed on the axis of the rotors, in a special chamber isolated from the compression chamber, are made of carbon steel.

The screws with the innovative profile with N-type operation "rolling" allow you to obtain the maximum discharge at the lowest power consumption with an extremely low noise generation.

The robust mechanics allows to operate with efficiency in the entire field of application and in all speeds of rotation permitted. The bearings mounted in tandem with a high degree of rigidity and precision of operation and resistant to the combination of axial and radial loads, protect the rotors against any rotations that might occur during system shutdown. These bearings have a special cages help to reduce noise and to increase the operational life of the compressors.

In the starting phase, since the pressures are always equalized inside the compressor, there is no circulation of oil, however, the bearings and the screws are designed to tolerate short periods (a few seconds) of operation "dry", waiting they establish the necessary pressure difference.

The three-stage oil separator ensures less migration of oil into the refrigerant circuit and at the same time better lubrication of the mechanical components of the compressors with a significant reduction in noise.

The semi-hermetic screw compressors are available, depending on size, with star-delta starting or dual stator winding separate "part winding", with a considerable reduction of inrush currents, which in an engine with direct starting values could reach three to 8 times higher than the maximum rated currents of operation. The semi-hermetic screw compressors are available with adjustment in steps or continuously with slide valve.

The first type of adjustment is obtained by the combination of three solenoid valves positioned in fixed positions on the body of the compressor that guarantee 4 steps of adjustment; the second is obtained from the combination of two solenoid valves, first one fixed position and the other one button, positioned also on the body of the compressor.

The capacity regulation is realized through a sliding drawer, "shutter", activated by oil pressure of the hydraulic circuit and controlled by solenoid valves positioned on the body of the compressor. The sliding drawer by acting on the volume aspirated by the bolts regulates the flow outlet and the cooling capacity generated by the compressor, resulting in a step change 25%, 50%, 75% and 100% in the first case, continuous from the minimum step at 100% in second.

The cooling capacity control of the compressor allows increased performance at partial loads with a consequent increase in the value ESEER.

The perfect centering of the rotors, in the axial and radial, is ensured by bearings mounted to the ends of the shafts.

The oil circuit will perform the following functions:

- Dynamic seal between the chambers
- Maintenance of a sliding drawer
- Lubricate the bearings and rotors
- Cooling of the moving parts
- Synchronization gear.

The oil circulation takes place by the pressure difference between the flow and the pressure of injection of oil, slightly higher than the suction pressure.

The oil and refrigerant mixture undergoes a first separation by virtue of the speed difference between the gas and the oil drops obtained for "Venturi" effect, a second separation as a result of centrifugal forces produced by special propellers and a third separation due to effect "filtering" through the parcel of the separator "Demister", easily accessible and replaceable, in which the oil droplets are subject to continuous changes of direction and speed. The oil, thus separated, is collected inside the oil pan, leaving free the surface of the "Demister", while the gas flows through the discharge valve.

This innovative system ensures a pressure drop below 0.6 bar and a separation efficiency of 99.98% even in the most critical conditions.

The compressor is equipped with non-return valve to prevent internal, at shutdown, the rotors rotate in opposite directions.

The compressor is equipped with a safety valve that connects the areas of high and low pressure. The valve is sized according to EN 60335-2-34 and opens at a differential pressure of 26 bar.

The motors are equipped with an electronic protection device model INT 69 FRY that controls over the temperature of the windings and the temperature of the gas flow in through PTC thermistors and probes mounted on the windings and on the high pressure side also the correct direction of rotation and the presence of the three phases. In more guarantees a start delay of at least 5 minutes in the case of overheating of the windings and a maximum number of 10 starts now. Screw compressors used have wide limits of operation and high values of COP.

The limited number of moving parts, dramatically reduces maintenance.

Special features of screw compressors used are extremely quiet, no vibration and therefore reduced pressure at the inlet pipes discharge pipes, low maintenance.

The compressors are also equipped as standard with:

- Taps delivery
- Upload oil
- Crankcase heater
- Oil Flow.

FANS

The technology of propeller fans, has blades statically and dynamically balanced, driven directly by the electric motors, closed type, external rotor and thermal protection for outdoor installation. Class F windings, internal protection according to VDE 0730. Ecoprofile are characterized by low speed and "owlet" profile to reduce the effect of vortices, thereby reducing the energy consumed for operation and noise, reducing it by an average of 6dB (A) compared with standard fans. All the sizes are equipped with the 2 steps condensing control (Δ/Y).

HIGH EFFICIENCY SHELL AND TUBE HEAT EXCHANGER – COLD SIDE

Direct expansion shell and tube type, high efficiency with low temperature approach between fluid and refrigerant, to reduce the temperature difference and increasing the evaporation temperature, improving the efficiency and reducing the power consumption. The steel shell is provided with water connections vitaulic and externally insulated with anti-condensate closed-cell (thickness of 10 mm and a thermal conductivity 0,033 W/mK a 0°C), in turn covered by a waterproof material resistant to UV rays.

The inner tubes are made of copper straight type with ruled surfaces, expanded on the tube plate of steel and complete with septa conveying water to optimize the thermal exchange. Designed for ecological fluids with speed inside the tubes

is not less than 10m/sec, such as to ensure the proper oil carryover. The shell and tube heat exchanger is built and tested according to PED regulations. The heat exchanger is protected against the formation of ice through an immersion electrical heater, controlled directly by the microprocessor as a function of the temperature of the water leaving the evaporator, is also installed a differential water pressure switch appropriately selected depending on the exchanger pressure drops as security against the lack of flow.

HIGH EFFICIENCY SHELL AND TUBE HEAT EXCHANGER – HOT SIDE

Direct expansion shell and tube type, high efficiency with low temperature approach between fluid and refrigerant, to reduce the temperature difference and increasing the evaporation temperature, improving the efficiency and reducing the power consumption. The steel shell is provided with water connections victaulic and externally insulated with anti-condensate closed-cell (thickness of 10 mm and a thermal conductivity 0,033 W/mK a 0°C), in turn covered by a waterproof material resistant to UV rays.

The inner tubes are made of copper straight type with ruled surfaces, expanded on the tube plate of steel and complete with septa conveying water to optimize the thermal exchange. Designed for ecological fluids with speed inside the tubes is not less than 10m/sec, such as to ensure the proper oil carryover. The shell and tube heat exchanger is built and tested according to PED regulations.

The heat exchanger is protected against the formation of ice through an immersion electrical heater, controlled directly by the microprocessor as a function of the temperature of the water leaving the evaporator, is also installed a differential water pressure switch appropriately selected depending on the exchanger pressure drops as security against the lack of flow.

SOURCE HEAT EXCHANGER

The condensing / evaporating exchangers are with finned coil and copper tubes, with corrugated fins of aluminum with spacing of the tubes 30/26 and spacing fins differentiated with fin pitch of 1.6mm at the top and 2.5mm at the bottom.

Thanks to the differentiated spacing is obtained a uniform speed profile across the coils so as to increase the heat exchange in the lower part especially critical in heat pumps.

On the basis of the coils are installed thermostated electrical heaters, immersed in the last row of tubes, in such a way that the heat develops around the entire pipe by increasing the conduction of heat. These electrical heaters are useful to prevent formation of ice on the batteries and to reduce the defrosting time favoring the drainage of the condensate.

Copper tubes are mechanically expanded, and are of a high efficiency with CROSS-GROOVED tube.

The batteries are also designed for ecological fluids, the velocity inside the tubes, not less than 10m/sec, are such as to ensure the correct entrainment of the oil in each load condition.

REFRIGERANT CIRCUIT

The patented refrigerant circuit is specific and optimized for the use of a reduced number of solenoids valve and the cross exchange technology, which allows to avoid stops of the units during winter times in case of hot water demand only when cooling is satisfied . Consequently the water temperature of the cold tank doesn't reach the temperature of ice on the evaporator.

The units are equipped with two independent refrigerant circuits, entirely constructed with copper tubes, each supplied by its own compressor, including:

- Refrigerant charge R134a
- Electronic expansion valve with stepper motor, suitable for ecologic refrigerant, with the control of the superheating within the whole operating range of the unit.
- Filter drier with interchangeable cartridge suitable for the use of ecological fluids and polyesters oils;
- Indicator lamp for liquid flow and humidity presence;
- Shut off valve on the liquid line complete of balancing pressure system making easier the opening and closing operations;
- High pressure switch;
- Low pressure switch;
- Pressure switch for the compressor oil to control the filter block;
- Safety valve on the discharge line;
- Safety valve on the suction line;
- High pressure trasducer;
- Low pressure transducers;
- Compressors discharge valve;
- Liquid receiver;
- Oil separator;
- 4 way reverse valve;
- Cycle configuration valve.

ELECTRICAL PANEL

The electrical panel made in accordance with CEI-EN 60204-1 (CEI44-5; CEI EN 62061) standards, is housed in watertight box, the opening system of the box needs the use of a retractable handle or dedicated tools, in each case the opening is allowed only after disconnection of the power supply through the main switch with door lock handle lockable in OFF position.

The electrical panel includes:

- Protection fuses for the supply line of each compressor;
- Protection fuses for the supply line of fans for each refrigerant circuit;
- Protection fuses of auxiliary circuit;
- Start up contactors for compressors dimensioned according to the maximum stress;
- Start up contactors for fans
- Adjustable thermal magnetic circuit breaker for the protection of the pump (only in case of units equipped with hydraulic kit)
- Start up contactors for pump (only in case of units equipped with hydraulic kit)
- single-phase transformer for the power supply of the auxiliary circuits
- numbered wires
- microprocessor control

In case of phase failure an automatic system protects fans and compressors.

The wiring of the electric panel and the connection with the components of the units are made using cables appropriately calculated for operation at 55°C and according to the maximum electrical stress of the components.

All the cables and the terminals are univocally numbered according to the electrical scheme in order to avoid possible misinterpretation. The identification system of the cables connected to the components allow also an easy and intuitive recognition of the component.

Each component of the electrical panel is provided with an identification plate according to what is shown on the electrical scheme. All the connection to the electrical panel are made from the bottom and are equipped with cover preventing from break.

The electrical panel supply is 400V/3ph+n/50Hz and no additional power supply is necessary. The input of the power cables is provided on the bottom of the box where it is provided a dismountable flange suitable for the purpose.

4.3 Operating Modes

The multi-functional units are made by 2 distinct sections, the hot one at condenser side, and the cold one at evaporator side: the simultaneous production of hot and chilled water allows the unit to adapt its operation to any requirement of the plant, in a totally autonomous and self-managed way. The multi-functional four pipes units automatically switch their operating cycle according to the load demands during the whole year, without doing the manual switch from summer to winter mode needed for the traditional heat pumps. There are three basic operating configuration which are automatically selected in order to minimize the power input and satisfy the thermal load of the plant.

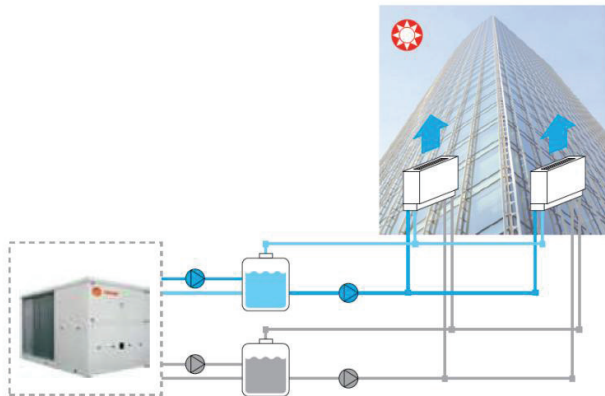

The unit works in chiller dissipating the condensation heat through a finned coil heat exchanger (condenser). The water is chilled in a water-refrigerant shell & tube heat exchanger (evaporator).

ONLY HEAT PUMP MODE

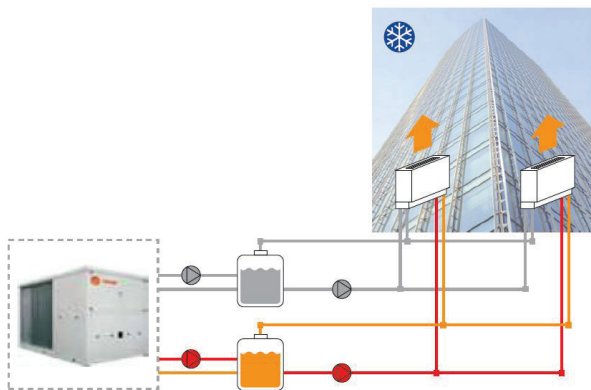

The unit works in heat pump mode only, exploiting the outdoor air energy to heat the water through a water-refrigerant shell & tube heat exchanger (condenser).

Differently from a traditional reversible heat pumps the hot water is produced through a different heat exchanger from those used to produce chilled water. Therefore according to the operating mode, whether the unit works in heat pump mode or in chiller mode, there will be a dedicated heat exchanger for the chilled or hot water production (evaporator or condenser).

This is required in order to keep the cold and hot sections separated, as needed in a 4-pipe system.

CHILLER + TOTAL OR PARTIAL RECOVERY MODE

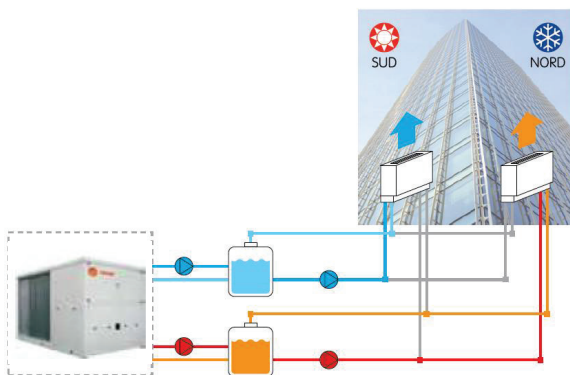

The unit works as a water-water heat pump if there's a simultaneous demand of hot and chilled water, by controlling the condensation and the evaporation through two different plates heat exchangers each for its own hydraulic circuit of the 4 pipe plant.

POSSIBLE OPERATING COMBINATIONS

HEATING LOAD %	COOLING LOAD %	CIRCUIT 1	CIRCUIT 2
100	100	C+R	C+R
75	25	H	C+R ^(PART LOAD)
50	50	R	OFF
50	25	H	C+R ^(PART LOAD)
25	0	H ^(PART LOAD)	OFF
75	0	H ^(PART LOAD)	H
100	0	H	H
50	100	C+R	C
25	75	C+R ^(PART LOAD)	C
50	50	OFF	C
100	50	H	C+R
50	75	C+R ^(PART LOAD)	C
50	25	H ^(PART LOAD)	C+R ^(PART LOAD)
50	0	H	OFF
25	75	C+R ^(PART LOAD)	C
25	50	C+R ^(PART LOAD)	C ^(PART LOAD)
25	25	C+R ^(PART LOAD)	OFF
25	0	H ^(PART LOAD)	OFF
0	100	C	C
0	75	C	C ^(PART LOAD)
0	50	OFF	C
0	25	OFF	C ^(PART LOAD)
0	0	OFF	OFF

C Chiller mode
H Heat pump mode
C+R Chiller + recovery mode

4.4 Compressor oil load

Oil circuit

The circulation of the oil is obtained by exploiting the pressure difference between the discharge pressure and the suction pressure. In the starting phase, since the pressures are always equalized inside the compressor, there is no circulation of oil, but the bearings and the screws are designed to tolerate short periods (a few seconds) of operation "dry", waiting for it to establish the necessary pressure difference. The lubricating oil has the following functions:

- Bearing lubrication
- Dynamic seal between the screws and the cylindrical chambers
- Control of the sliding drawer (throttle) for adjusting the capacity
- Cooling of bearings and temperature uniformity

Inside the compressor the oil is contained in the sump, flowing in the lubrication circuit via a filter and reaches the injection points on the bearings and on the screw and towards the cylinder of the sliding drawer that regulates the capacity control.

Capacity control.

Pressure control oil circulation.

The correct amount of oil, so the oil performs all its functions (lubrication, sealing, sliding drawer control (throttle), cooling), is ensured when the compressor operates within the scope set with filter normally clean and oil with its own physical characteristics intact.

The total volumetric flow rate of the oil is due to the operating conditions (pressure) and the type of refrigerant.

The oil circuit of the compressor is designed for:

- Minimum volumetric flow rate of 4 liters / min (calibration set of the oil flow switch)
- Maximum volumetric flowrate of 24 liters / min

The amount of oil loaded at the factory in the compressor are listed in the card catalogs and technical. Depending on the type of plant and the working conditions of the compressor may be necessary to add a certain amount of oil to the initial charge. Consider also the presence of the oil cooling circuit. The oil level in the compressor must be examined when the compressor is running. The compressor is equipped with two LEDs to display the oil level, made on cast iron in the vicinity of the oil sump.

- The upper indicator indicates the optimal level for the correct operation
- The lower indicator indicates the minimum level below which it can not work

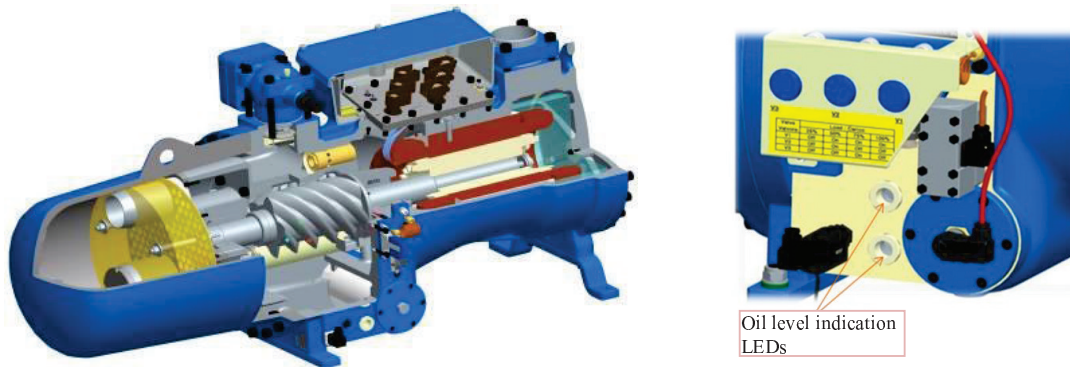

Filter oil

The compressors are equipped with an oil filter flange directly into the oil sump. The filter with filter element easily replaceable, has a high efficiency and a pressure drop below 0.6 bar.

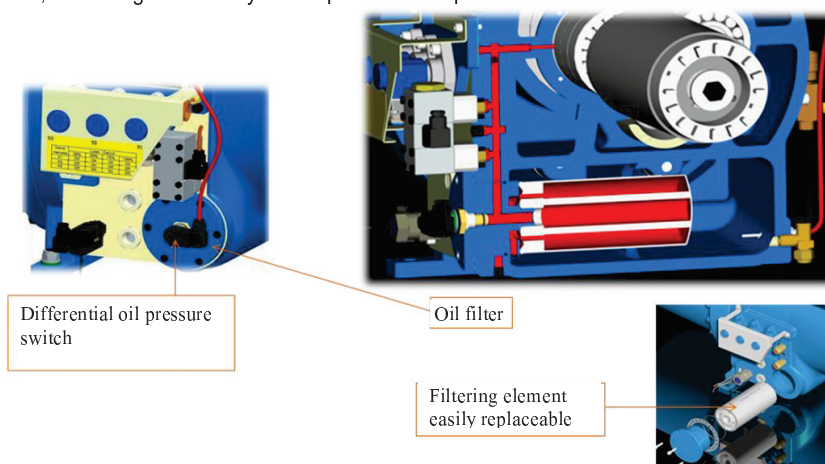

Lubricating oil

The lubricating oil shall be:

- Good viscosity characteristics at high temperatures;
- Good miscibility with the refrigerant at low temperatures;

The compressors CX can be loaded with the following oil lubricants approved by the manufacturer:

POE UNIQUEMA RL170H
POE CASTROL ICEMATIC SW170
POE CPA SOLEST 170
POE FUCS RENISO TRITON SA170
POE MOBIL EAL ARTIC 170
POE FRASCOLD FC170

Oil heater

The compressors are equipped with a resistance tube inserted into a well made in the fusion

The heating oil has the aim to prevent excessive dilution of the refrigerant in the oil

- The resistance is already thermostated and not need to be interfaced with the compressor contactor.

The resistor is already installed at the factory

- Power 300 Watt
- Power 230-1-50/60 (others on request)
- Calibration thermostated 70 ° C (optimal temperature oil)

Resistance is not have direct contact with the oil, its possible repositioning is made extremely easy

The heating of the oil is necessary in all cases:

- Downtimes compressor
- Danger of condensation of the refrigerant inside the compressor
- High refrigerant charge
- Installations in cold environments
- At the first start-up and subsequent closure period starts after far the resistance should be on 24 oreprima starting the compressor



Lubricating monitoring

Flow switch

The control of the flow of oil in the internal circuit of the compressor can be controlled by the flow switch

The compressors are designed for the Sumava of the device (ask the manufacturer). Through a pair of connections the flow switch is connected to the oil circuit and monitors signaling the actual passage of oil in the circuit irrespective of the quantity of oil in the sump. Connected in series with the chain of alarms, this device provides a high degree of safety to the operation of the compressor.

- Calibration set to 4 liters / min
 - Contact type Reel (electromagnetic), open contact on the correct flow, flow properly closed contact
 - It requires that the flow switch has the appropriate delays (not supplied by the manufacturer)
- In Ignition (between 10 and 20 seconds)
- In operation (5 seconds)

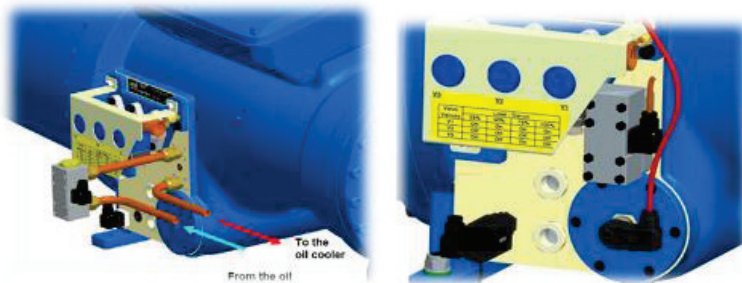

Oil Compressor temperature control

The compressors are fitted with a device for monitoring the oil temperature

The compressors are designed to monitor the correct oil temperature through a PTC sensor installed directly into the cup dell'olio

A special protection of the compressor in addition to monitoring the temperature of the electric motor and the oil (T. outlet), through the proper operation of the thermistor chain, the verification module:

- the presence of the phases
- the direction of rotation at start
- the start-up delay (5 minutes) in the case of motor overheating
- the maximum number of starts per hour (10 in a rolling window of 60 minutes)



Power supply to the auxiliary circuit

The connection to the power circuit is internal to the panel and is performed in the factory. The compressor oil heaters, guards against the overheating of the compressor, and the probe safety chilled water are connected so as to be operational always, as long as there is power to the electrical panel.

4.5 Cooling/Heating capacity control

The control of the compressor capacity is achieved by varying, through VFD, the speed of rotation of the same in the range between 1200 and 4500 rpm, the compressor capacity varies as well, so roughly linear between 27% and 100% of the nominal capacity.

Should it be required, and if the conditions of operation of the compressor so allowed, the speed of rotation of the compressor can be pushed to 5400 rpm, reaching a capacity equal to 120% of the nominal one.

The overboost limit is given by the maximum output power from the VFD and the compliance with the conditions of operation reliable compressor, and may thus vary depending on the ambient temperature and the temperature chilled water.

The drawers of capacity typical of screw compressors although present, Come used only at startup and stop the compressor ensuring, however, the start of the compressor with minimum torque and then with minimal inrush current.

5 Pre start up checks

5.1 General

Once the machine has been installed, use the following procedure to check that it has been done properly:



WARNING

Remove the power supply from the machine before performing any checks.
Failure to open the power switches at this stage can result in serious injury to the operator or even death.

Inspect all the electrical connections to the power circuits and to the compressors including the contactors, fuse carriers and electrical terminals and check that they are clean and well secured. Even though this is done at the factory to every machine that is shipped, vibrations from transport could have loosened some electrical connections



WARNING

Check that the electrical terminals of cables are well tightened. A loose cable can overheat and give rise to problems with the compressors.

Open discharge, liquid, liquid injection and intake (if installed) taps.



WARNING

Do not start up the compressors if the exhaust, liquid, liquid injection and intake taps are closed. Failure to open these taps/ valves can cause serious damage to the compressor.

Place all the thermal-magnetic switches of the ventilators



WARNING

If the thermal-magnetic switches of the ventilators are forgotten open, both compressors will block due to high pressure when the machine is started up for the first time. Resetting the high-pressure alarm requires opening the compressor compartment and resetting the high-pressure mechanical pressure switch.

be the same as that on the nameplate. Maximum allowed tolerance +/- 10%.

Voltage unbalance between the three phases must not exceed +/- 3%.

The unit comes with a factory-supplied phase monitor that prevents compressors from starting in the event of an erroneous phase sequence. Properly connect the electrical terminals to the disconnect switch so as to ensure alarm-free operation. In the event that, after the machine has been powered on, the phase monitor should set off an alarm, only invert two phases at the general disconnect switch input (Unit input). Never invert the electrical wiring on the monitor.



WARNING

Starting up with the wrong sequence of phases irreparably compromises operation of the compressor. Ensure that phases L1, L2 and L3 correspond in sequence to R, S and T ..

Fill the water circuit and remove air from the system's highest point and open the air valve above the evaporator skirt. Remember to close it again after filling. The design pressure on the water side of the evaporator is 10.0 bars. Never exceed this pressure at any time during the life of the machine.

▲ WARNING

Before placing the machine into operation, clean the hydraulic circuit. Dirt, incrustation, corrosion residue and other extraneous material can accumulate in the heat exchanger and reduce its thermal exchange capacity. Pressure drops can also increase, consequently reducing water flow. Thus, correct water treatment reduces the risk of corrosion, erosion, scaling, etc. The most appropriate water treatment must be established locally, according to the type of installation and to the characteristics of the process water locally. Trane is not responsible for damage or bad operation of the apparatus resulting from failure to treat water or from incorrectly treated water.

Close the door lock main switch placed on the door of the main electrical panel and move the switch On position Make sure that the display shows: "Unit in stand-by."

▲ WARNING

From this moment on, the machine will be electrically powered. Use extreme caution in operations later. Failure WARNING, in subsequent activities, can cause serious harm to people

5.2 Electrical supply

The supply voltage of the machine must be equal to that specified on the rating plate $\pm 10\%$, while in voltage unbalance between phases must not exceed $\pm 3\%$. Measure the voltage between phases and whether the measured value is not within the limits, provide for its correction before the machinery.

▲ WARNING

Provide an adequate supply voltage. Inadequate supply voltage may cause malfunction of control components and unwanted interventions thermal protection as well as a substantial reduction of the life of the contactors and electric motors.

Unbalance in power supply voltage

In a three phase system the excessive unbalance between the phases is the cause of the overheating of the engine. The maximum allowed voltage unbalance is 3%, calculated as follows:

$$\% \text{ Phase unbalance} = \frac{V_{\max} - V_{\text{average}}}{V_{\text{average}}} * 100$$

Unbalance between phases in the power supply

Do not operate the electric motors when the unbalance voltage between the phases is greater than 3%. Use the following formula for the control::

$$\% \text{ Phase unbalance} = \frac{\text{Max deviation from the average voltage}}{\text{Average voltage}} * 100$$

Important

If the grid voltage has an imbalance greater than 3%, contact the company for distribution of electricity. Operating the unit with a bias voltage between phases over 3% is inhibited or lose the warranty.

Electrical resistances power supply

Each compressor comes with an electrical resistance located in the compressor's lower area. Its purpose is to warm the lubricating oil and thus avoid the transmigration of refrigerant fluid within.

It is therefore necessary to ensure that the resistances are powered at least 24 hours before the planned startup time. To ensure that they are activated, it is sufficient to keep the machine on by closing the general disconnecting switch Q10.

The microprocessor, however, has a series of sensors that prevent the compressor being started up when the oil temperature is not at least 5°C above the intake-pressure equivalent saturation temperature.

Keep the Q0, Q1, Q2 and Q12 switches in the Off (or 0) position until the machine is to be started up.

5.3 Startup preliminary procedures

Initial controls

Before starting the unit, even only momentarily, all the machinery supplied by the chilled water, like the air handling units, pumps, etc. have to be checked. The pump auxiliary contacts and the flow switch have to be connected to the control panel as indicated in the electrical diagram. Before carrying out interventions on the valve regulations, loosen the relevant valve gland. Open the discharge valve of the compressor. Open the liquid shutoff valve placed on the liquid line. Measure the suction pressure. If it is lower than 0.42 MPa jumper and strain the solenoid valve on the liquid line. Bring the suction pressure to 0.45 MPa, then remove the jumper. Charge all the water circuit progressively. Starts up the water pump of the evaporator with the calibration valve shut and then slowly open it.

Discharge the air from the high points of the water circuit and check the direction of the water flow. Carry out calibration of the flow by using a measurer (if present or available) or by means of a combination of the readings of the manometers and the thermometers. In the starting phase calibrate the valve on the pressure difference read on the manometers, carry out drainage of the tubes and then carry out fine calibration on the temperature difference between the water in and the water out. The regulation is calibrated in the factory for water in to the evaporator at 12°C and water out at 7°C. With the general switch open, check that the electrical connections are tightly clamped. Check for any possible refrigerant leaks. Check that the electrical data on the label correspond to those of the mains supply. Check that the thermal charge available is appropriate for starting.

Refrigerant seals control

Trane units are sent with the complete charge of refrigerant and are at a sufficient pressure to check the seal after installing. If the system were not under pressure, blow refrigerants (vapour) into it until pressure is reached and look for leakage.

After having eliminated the leakage, the system has to be dehydrated with a vacuum pump up to at least 1 mm Hg - absolute pressure (1 Torr or 133.3 Pa). This is the minimum recommended value to dehydrate the plant.

Dangers do not use the compressor to vacuum the system.

Refrigerant charge check

Trane units are supplied with a complete charge of refrigerant. If bubbles can be seen through the peephole with the compressor running with a full charge and steadily, it means that the refrigerant charge is insufficient.

Danger While refrigerant is being added do not exclude any control system and let the water circulate in the evaporator to avoid the formation of ice.

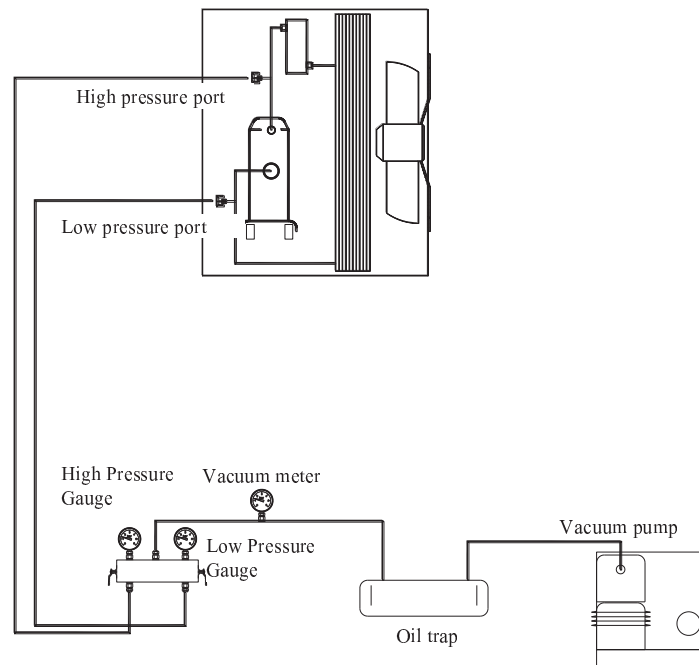

5.4 Check list – mandatory operation control before start up

DATE		N.	
UNIT			

CUSTOMER:	SITE:
	ADDRESS:
	POSTCODE:
	COUNTRY:

THE INTENDED PURPOSE OF HEVA QUATTRO AND QUATTRO PROZONE MACHINES IS NOT FOR INDUSTRIAL APPLICATION. PLEASE CONTACT THERMOCOLD TECHNICAL DEPARTMENT IN CASE OF INDUSTRIAL APPLICATION.

GENERAL

		COMPLIANCE	
		YES	NO
1	<p>THE HYDRAULIC CIRCUIT IS COMPLETE AND READY TO BE USED AND THE THERMAL LOAD IS AVAILABLE.</p> <p>PLEASE NOTE THAT THE FIRST START-UP SHALL NOT BE CARRIED OUT UNLESS THE PLANT IS READY AND THE WATER LOAD IS AVAILABLE.</p>		
2	<p>THE UNIT DISPLAYS DENTS OR DAMAGES ON THE EXTERNAL CASING OCCURRED DURING THE TRANSPORTATION OR POSITIONING.</p> <p>IF ANY, SPECIFY BELOW:</p> <p>WARNING: PLEASE BE AWARE THAT RELEVANT DAMAGES CAUSED BY THE QUOTED CIRCUMSTANCES MAY RESULT IN THE CALL-OFF OF THE WARRANTY.</p>		
3	THE UNIT HAS BEEN INSTALLED IN ACCORDANCE WITH THE MINIMUM DISTANCE PROVIDED IN THE DIMENSIONAL DRAWING AND TECHNICAL DOCUMENTATION PROVIDED.		
4	THE UNIT IS INSTALLED NEXT TO THE: PHOTOVOLTAIC SYSTEM, ELECTRONIC TRANSMITTERS, ANTENNAS OR SIMILAR DEVICES.		
5	THE UNIT IS POSITIONED ON A PERFECTLY FLAT (NOT INCLINED) SURFACE.		
6	ANTI-VIBRATIONS DAMPERS HAVE BEEN INSTALLED BETWEEN THE UNIT AND THE FLOOR.		
7	<p>THE UNIT DISPLAYS DEFECTS OR DAMAGES RESULTING FROM MODIFICATIONS OR CHANGES (UNIT TAMPERING / UNAUTHORIZED MODIFICATIONS TO THE REFRIGERANT CIRCUIT OR THE HYDRAULIC CIRCUIT OR THE ELECTRICAL PANEL OR CHANGES TO THE UNIT OPERATING PARAMETERS) MADE BY A THIRD PERSON WITHOUT A WRITTEN AUTHORIZATION ISSUED BY TRANE. THE UNIT SHALL BE CONFORM TO TRANE WIRING DIAGRAMS AND TECHNICAL DOCUMENTATION) IN CASE OF RELEVANT DIFFERENCE BETWEEN THE UNIT AND TRANE STANDARD CONFIGURATION PLEASE CONTACT TRANE.</p> <p>WARNING: PLEASE BE AWARE THAT RELEVANT DAMAGES CAUSED BY THE QUOTED CIRCUMSTANCES MAY RESULT IN THE CALL-OFF OF THE WARRANTY.</p>		

INSTALLATION OPERATION MAINTENANCE

8	THE UNIT HAS BEEN INSTALLED VERY CLOSE TO A MARINE ENVIRONMENT OR AN AGGRESSIVE INSTALLATION ENVIRONMENT (HIGHLY CORROSIVE CHEMICAL AGENT). WARNING: PLEASE BE AWARE THAT RELEVANT DAMAGES CAUSED BY THE QUOTED CIRCUMSTANCES MAY RESULT IN THE CALL-OFF OF THE WARRANTY.		
9	SPOTTED PRESENCE OF MOLD, MUSHROOMS, BACTERIA, MICROBIAL OF ANY TYPE.		
10	THE UNIT DISPLAYS DAMAGES CAUSED BY: FLOODS, LIGHTNING, FIRE, ANY ACCIDENT BEYOND TRANE'S CONTROL.		

ELECTRIC AND ELECTRONIC

11	THE UNIT IS ELECTRICALLY POWERED AND ALL THE RELEVANT ELECTRICAL WIRES ARE PROPERLY CONNECTED.		
12	ELECTRICAL SUPPLY HAS BEEN INSTALLED IN ACCORDANCE WITH THE INSTRUCTIONS PROVIDED IN THE NAME PLATE AND IN THE TECHNICAL DOCUMENTATION. (ELECTRICAL POWER SUPPLY: 230V/400V +/- 10% - MAXIMUM "% OF PHASE IMBALANCE: +/- 3%) . IT IS RECOMMENDABLE TO CHECK BY USING A TESTER THE VOLTAGE VALUE (BETWEEN PHASES AND BETWEEN PHASE AND NEUTRAL)		
13	PHASES ARE CONNECTED IN THE PROPER SEQUENCE.		
14	ELECTRICAL CABLES SIZE ARE CONFORM TO FLA MAX VALUE.		
15	BOTH EXTERNAL AND INTERNAL ELECTRICAL WIRES ARE WELL TIGHTENED.		
16	THE COMPRESSOR CRANCKCASE HEATERS HAVE BEEN POWERED AND HEATED AT LEAST 8 HOURS BEFORE THE START-UP.		
17	AN ELECTRONIC SUPERVISOR (OR ANY ADDITIONAL CONTROLLER) HAS BEEN INSTALLED.		
18	THE CONNECTION WIRES ARE SHIELDED.		
19	REMOTE CONTROL DEVICES OR INTERFACES ARE CONNECTED TO THE ELECTRICAL PANEL IN CONFORMITY WITH TRANE WIRING DIAGRAMS.		
20	ELECTRIC DEVICES ARE INTACT AND DON'T DISPLAY ANY DAMAGE.		
21	ELECTRONIC DEVICES ARE INTACT AND DON'T DISPLAY ANY DAMAGE.		
22	WATER PUMPS ARE ELECTRICALLY CONNECTED TO THE ELECTRICAL PANEL IN ACCORDANCE WITH THE WIRING DIAGRAMS PROVIDEDBY TRANE.		
23	THE ELECTRICAL ABSORPTION AND THE WATER PUMPS OVERHEATING ARE STANDARD.		

REFRIGERANT CIRCUIT

24	ALL CONNECTIONS ON THE REFRIGERANT CIRCUITS ARE WELL TIGHTENED.		
25	THE ELECTRONIC LEAKAGE DETECTOR OR THE PRESSURE GAUGE LEVEL INSTALLED ON THE REFRIGERANT CIRCUIT HAVE DETECTED ANY LEAKAGE. IF ANY, SPECIFY BELOW:		
26	THE COMPRESSOR OIL INDICATOR LIGHT POINTS THE MAXIMUM LEVEL.		
27	THE FILTER INDICATOR LIGHT ON THE LIQUID LINE IS GREEN. WARNING: THE YELLOW INDICATOR LIGHT INDICATES PRESENCE OF MOISTURE IN THE CIRCUIT. IN THIS CASE PLEASE CONTACT TRANE.		

WATER CIRCUIT

28	THE FILTER IS INSTALLED ON BOTH HEAT EXCHANGERS INLET PIPES, AT A MAXIMUM DISTANCE OF 2 METERS FROM THE UNIT. PLEASE NOTE THAT THE FILTER INSTALLATION IS MANDATORY . FOR FURTHER TECHNICAL INFORMATION RELATING THE FILTER PLEASE REFER TO THE TECHNICAL DOCUMENTATIONS.		
29	THE FLOW SWITCH HAS BEEN INSTALLED AND ELECTRICALLY CONNECTED. PLEASE NOTE THAT FLOW SWITCH INSTALLATION IS MANDATORY .		
30	THE VALVES ON THE WATER PLANT MUST BE OPENED. PLEASE BE AWARE THAT IF THE MACHINE IS POWERED (OR IN STAND-BY MODE) PUMPS WILL START IF THE WATER TEMPERATURE IS EQUAL OR BELOW 4°C. CLOSING THE VALVES MAY THEREFORE CAUSE SEVERE DAMAGES.		
31	DRAINAGE VALVES ARE INSTALLED. THE DRAINAGE VALVES ARE INSTALLED ON THE LOWEST POINT. THE UTILIZATION OF AUTOMATIC DRAINAGE VALVES IS RECOMMENDED.		
32	AUTOMATIC OR MANUAL PURGE VALVES ARE INSTALLED. AUTOMATIC OR MANUAL PURGE VALVES ARE INSTALLED ON THE HIGHEST POINT.		
33	THE HYDRAULIC CIRCUIT HAS BEEN FILLED AND PURGED. THE PLANT SHALL BE PURGED SEVERAL TIMES BEFORE STARTING UP THE UNIT. THE FILTER INSTALLED NEXT TO THE HEAT EXCHANGER SHALL BE CLEANED SEVERAL TIMES BEFORE STARTING UP THE UNIT, UNTIL THE CORRECT DELTA T IS ASSURED AND THE HYDRAULIC PRESSURE IS CONFORM TO THE PLANT AND TO THE WATER PRESSURE DROPS. FOR FURTHER TECHNICAL INFORMATION PLEASE REFER TO TRANE DOCUMENTATIONS AND PROCEDURE FOR THE		

INSTALLATION OPERATION MAINTENANCE

	FIRST START UP.		
34	HYDRAULIC CONNECTIONS TO THE UNIT ARE COMPLIANT WITH THE UNIT NAME PLATE AND DIMENSIONAL DRAWINGS (HOT WATER INLET, HOT WATER OUTLET, COLD WATER INLET, COLD WATER OUTLET, EXT.)		
35	RUBBER JOINTS ARE INSTALLED ON THE HYDRAULIC CONNECTIONS, IN ORDER TO MINIMIZE VIBRATIONS BETWEEN THE UNIT AND WATER PIPES.		
36	SHUTOFF VALVES ARE INSTALLED ON THE HYDRAULIC CIRCUIT.		
37	THE EXPANSION TANK IS INSTALLED ON THE HYDRAULIC CIRCUIT. EXPANSION TANK CAPACITY CONCURS WITH THE WATER PLANT CAPACITY.		
38	TEMPERATURE PROBES AND PRESSURE GAUGES ARE INSTALLED ON THE HYDRAULIC CIRCUIT, BOTH INLET AND OUTLET SIDE.		
39	THE HYDRAULIC CIRCUIT IS FREE FROM OBSTRUCTION OR ANY KIND OF CONSTRAINT.		
40	<p>BUFFER TANKS ARE INSTALLED IN THE HYDRAULIC CIRCUIT. THE BUFFER TANKS INSTALLATION IS STRONGLY RECOMMENDED IN ORDER TO GUARANTEE THE OPTIMAL UNIT OPERATION.</p> <p>SPECIFY HOT BUFFER TANK CAPACITY: _____ LT</p> <p>SPECIFY COLD BUFFER TANK CAPACITY: _____ LT</p>		
41	<p>THE PRESSURE RELIEF VALVE IS INSTALLED BETWEEN DELIVERY AND RETURN PIPES .</p> <p>WARNING: IN ORDER TO AVOID <u>WATER-HAMMER</u>, THE RELIEF VALVE PRESSURE SHALL BE SET UP IN ACCORDANCE WITH THE STANDARD OPERATING PRESSURE OF THE WATER CIRCUIT.</p>		
42	<p>THE AUXILIARY HEATING SYSTEM IS INSTALLED IN THE WATER CIRCUIT IN ORDER TO AVOID THE START-UP OF THE UNIT WITH WATER TEMPERATURE BELOW 18°C. BEFORE STARTING UP THE UNIT THE INLET WATER TEMPERATURE MUST BE EQUAL OR HIGHER THAN 18°C.</p> <p>WARNING: THE UNIT SHALL NEVER WORK (NOT EVEN FOR SHORT PERIODS) WITH AN INLET WATER TEMPERATURE LOWER THAN 18°C.</p>		
43	<p>ANTIFREEZE PROTECTIONS ARE INSTALLED IN THE WATER CIRCUIT (ELECTRICAL HEATERS ARE INSTALLED ON WATER PIPES AND TANKS).</p> <p>FOR FURTHER TECHNICAL INFORMATION PLEASE REFER TO TECHNICAL DOCUMENTATION PROVIDED. PLEASE NOTE THAT ANTIFREEZE PROTECTIONS ARE MANDATORY FOR OUTDOOR AIR TEMPERATURES LOWER THAN 3°C.</p>		
44	THE WATER CIRCUIT IS FILLED WITH ETHYLENE GLYCOL. ETHYLENE GLYCOL "%" SHALL BE CONFORM WITH THE DATA PROVIDED IN THE TECHNICAL DOCUMENTATION.		
45	ALL WATER PIPES ARE GROUND CONNECTED (IN ORDER TO AVOID ABNORMAL VOLTAGES THAT CAN CAUSE DANGEROUS CORROSIONS).		

46	THE EVAPORATOR WATER FLOW IS COMPLIANT TO THE TECHNICAL DOCUMENTATION PROVIDED BY TRANE.		
47	THE WATER PUMPS ARE CORRECTLY SET UP IN ACCORDANCE WITH THE PLANT WATER FLOW, AVAILABLE HEAD PRESSURE AND PRESSURE DROP.		
48	THE PUMP IMPELLERS ARE MECHANICALLY UNBLOCKED AND UNCLOGGED (FREE FROM ANY KIND OF CONSTRAINT).		

DATE:	<u>AUTHORIZED SERVICE:</u> <u>NAME AND SIGNATURE</u>	<u>CUSTOMER:</u> <u>NAME AND SIGNATURE</u>
--------------	---	---

5.5 Refrigerant replacement procedure

1. If the machine has exhausted the refrigerant, it is necessary first of all to establish the causes, before carrying out any replenishment operation. The leak must be looked for and repaired. Oil stains are a good indicator, as they can appear in the vicinity of a leak. However, this is not necessarily always a good search criterion. Searching with soap and water can be a good method for medium to large leaks, while an electronic leak searching device is required to find the position of small leaks.
2. Add refrigerant to the system through the service valve located on the intake pipe or through the Schrader valve located on the evaporator entry pipe.
3. The refrigerant can be added under any load condition between 25 and 100% of the circuit. Intake overheating must be between 4 and 6°C.
4. Add enough refrigerant to fill the liquid pilot lamp entirely, until the passage of bubbles inside stops. Add an extra 2 ÷ 3 kg of refrigerant as a reserve, to fill the undercooler if the compressor is operating at 50 – 100% load.
5. Check the undercooling value by taking the liquid pressure and the liquid's temperature near the expansion valve. The undercooling value must be between 4 and 8 °C and between 10 and 15°C machines with an economiser. The undercooling value will be lower 75 to 100% of the load and above 50% of the load.
6. With ambient temperature above 16°C, all ventilators should be on.
7. A system overcharge will entail a rise in the compressor's discharge pressure, owing to excessive filling of the condenser section pipes

Table - Pressure/Temperature

R134a Pressure /Temperature table							
°C	Bar	°C	Bar	°C	Bar	°C	Bar
-14	0.71	12	3.43	38	8.63	64	17.47
-12	0.85	14	3.73	40	9.17	66	18.34
-10	1.01	16	4.04	42	9.72	68	19.24
-8	1.17	18	4.37	44	10.30	70	20.17
-6	1.34	20	4.72	46	10.90	72	21.13
-4	1.53	22	5.08	48	11.53	74	22.13
-2	1.72	24	5.46	50	12.18	76	23.16
0	1.93	26	5.85	52	13.85	78	24.23
2	2.15	28	6.27	54	13.56	80	25.33
4	2.38	30	6.70	56	14.28	82	26.48
6	2.62	32	7.15	58	15.04	84	27.66
8	2.88	34	7.63	60	15.82	86	28.88
10	3.15	36	8.12	62	16.63	88	30.14

Refrigerant charge

Charge with unit stopped and in vacuum (refrigerant charge in the liquid phase)

Completely open the valve for it to close the service connection. Connect the refrigerant cylinder to the service connection without tightening the connection. Half close the liquid shut off valve. If the circuit has been dehydrated and vacuum, load liquid with the cylinder upside down. Weigh and charge the appropriate amount. Open the valve completely. Start the unit and let it run at full load for several minutes. Check that the indicator is clear and without bubbles. Be sure that the transparency condition without bubbles is due to the liquid and not to the vapor. For correct unit operation overheating must be at 4 to 7 ° C and subcooling at 4 - 8 ° C. Too high values of overheating can be caused by a lack of refrigerant, while high values of subcooling may indicate excess charge.

After changing the charge, you should check that the unit works within the declared values: in full load operation, by measuring the temperature of the intake pipe downstream of the bulb of the thermostatic valve; read the equilibrium pressure on the evaporator on the low pressure gauge and the corresponding saturation temperature.

Overheating is equal to the difference between the measured temperatures. Measure then the temperature of the pipe of liquid leaving the condenser and detect on the high-pressure gauge the equilibrium pressure on the condenser and the corresponding saturation temperature. Subcooling is the difference between these temperatures. Charge is in the liquid phase

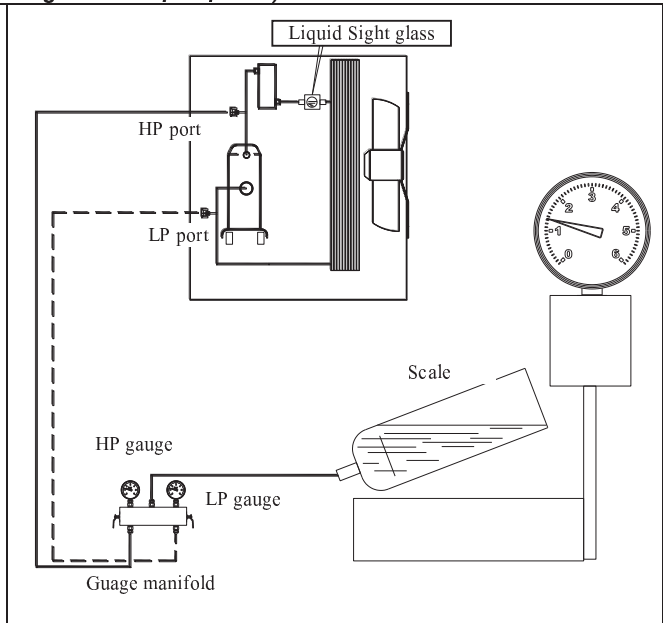

Refrigerant charge addition with the unit running (refrigerant charge in the vapour phase)

Caution: Charge only vapor. Do not charge liquid because it may damage the compressor. Connect the cylinder to the service connection without tightening the connection. Drain the connecting pipe and tighten the connection. Charge each circuit until the indicator shows liquid without bubbles. The unit now has an adequate charge. Be careful not to overload the circuit. Loading more than necessary leads to higher outlet pressure, higher power consumption and possible damage to the compressor. Charge is in the vapor phase

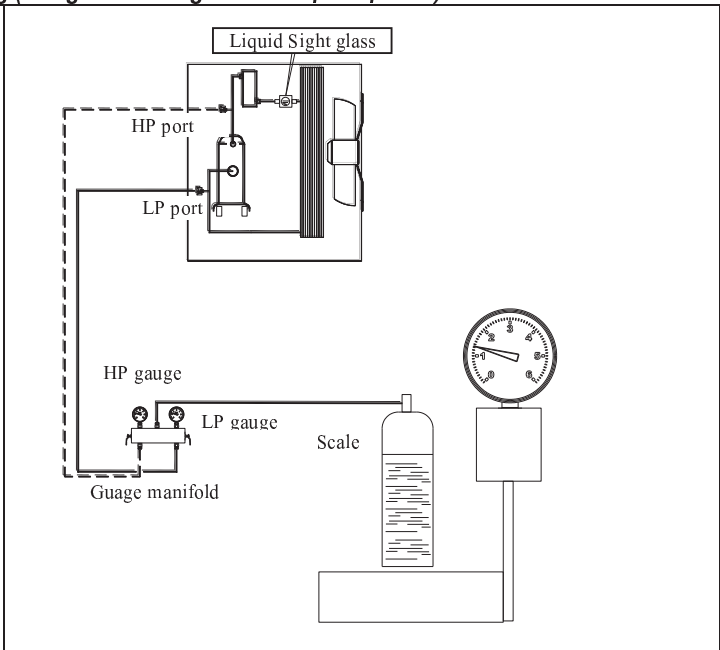

▲ WARNING

The symptoms of a low refrigerant charge are:

- Low evaporation pressure
- High superheat the intake and exhaust (outside the above limits)
- Low value of subcooling.

In this case, add refrigerant R134a in the corresponding circuit. The system is planned charging port between the expansion valve and the evaporator. Charge refrigerant until conditions return to work normal.

Remember to replace the cap closing the valve at the end.

▲ WARNING

If the machine has not been provided with integrated pump on board, do not turn off the external pump before You do not 3 minutes have elapsed after turning off the last compressor. The early shutdown of the pump Causes a water flow alarm failure.

Seasonal shutdown

1. Turn switches Q1 and Q2 to the Off (or 0) position to shut down the compressors, using the normal pumpdown procedure.
2. After the compressors have been shut down, turn switch Q0 to Off (or 0) and wait for the built-in water pump to shut down. If the water pump is managed externally, wait for 3 minutes after the compressors have shut down before turning off the pump.
3. Open the Q12 (Off position) thermal magnetic switch inside the control section of the electrical board then open the general disconnecter switch Q10 to cut off the machine's power supply entirely.
4. Close the compressor intake taps (if any) and delivery taps and also the taps located on the liquid and liquid injection line.
5. Place a warning sign on every switch that has been opened, advising to open all the taps before starting the compressors.
6. If no water and glycole mixture has been introduced into the system, discharge all the water from the evaporator and from the connected piping if the machine is to remain inactive during the winter season. One must remember that once the machine's power supply has been cut off, the antifreeze electrical resistance cannot function. Do not leave the evaporator and piping exposed to the atmosphere during the entire period of inactivity.

Starting up after seasonal shutdown

1. With the general disconnecter switch open, make sure that all the electrical connections, cables, terminals and screws are well tightened to ensure good electrical contact.
2. Verify that the power supply voltage applied to the machine is within • +/- 10% of the nominal nameplate voltage that the voltage unbalance between phases is between • +/- 3%.
3. Verify that all control apparatus is in good condition and functioning and that there is a suitable thermal load for startup.
4. Verify that all the connection valves are well tightened and that there are no refrigerant leaks. Always reposition the valva caps.
5. Verify that switches are in the open position (Off). Turn the general disconnecter switch to the On position. Doing this will allow to turn on the electrical resistances of the compressors. Wait at least 12 hours for them to start up.
6. Open all intake, delivery, liquid and liquid injection taps. Always reposition tap covers.
7. Open the water valves to fill the system and bleed air from the evaporator through the air valve installed on its shell. Verify that there are is no water leakage from piping.

5.6 Refrigerant loading

WARNING

The units are designed to work with R134a refrigerant. DO NOT USE therefore different refrigerants from 'R134a

WARNING

The addition or removal of refrigerant gas must be done in accordance with the laws and regulations in force.

WARNING

When you add or remove the refrigerant from the system, ensure the proper flow of water through the evaporator for the entire period of charge / discharge. The interruption of the flow of water during this procedure would result in the freezing of the evaporator resulting in rupture of its internal pipes. Damage due to freezing will void the warranty.

WARNING

The removal of refrigerant and charging the battery should be made by qualified technicians in the use of material appropriate for the unit. Improper maintenance can lead to uncontrolled pressure loss and fluid. Also does not disperse the refrigerant and the lubricating oil in the environment. Always wear a special system of recovery.

Units are shipped with the total refrigerant charge, but there might be cases where it is necessary recharge the vehicle on the ground.

WARNING

Always check the causes that have led to a loss of refrigerant. If necessary, repair the system and then proceed to its charging.

The charging of the machine can be made in any load condition stable (preferably between 70 and 100%) and in every condition of temperature (preferably higher than 20 ° C). The machine should be maintained turned on for at least 5 minutes to allow the stabilization of the steps of the fans, and then the pressure of condensation.

The units have about 15% of the condensing coils dedicated to the subcooled liquid refrigerant. the value of subcooling is equal to about 5-6 ° C (10-15 ° C for machines economized).

Once the section sottoraffreddante has been completely filled. a further quantity of refrigerant is not increases the efficiency of the system. However a small amount of additional refrigerant (1 ÷ 2 kg) makes the system less sensitive.

Note: By varying the load and the number of active fans, subcooling varied and requires some time to restabilize. However it should never drop below 3 ° C in all conditions. Furthermore, the value of subcooling may change slightly with changes in temperature of the water and the superheat of suction.

One of the following two scenarios may occur in a machine discharge of refrigerant:

1. If the machine is slightly discharge of refrigerant through the sight glass you can see the passage of bubbles. The circuit as described in the charging process.
2. If the machine is moderately gas discharge, the corresponding circuit could have stops low pressure. Prime the circuit as described in the corresponding charge.

6 Start up

6.1 Preliminary checks

Before starting the appliance it is very important verify that you have correctly performed all the operations described in the section "PREPARATION OF STARTING."

Also check that all mechanical and electrical equipment are tightened properly. WARNING particular should be paid to the fundamental components (compressor, heat exchangers, fans, electric motors, pumps, terminal blocks) are detected in the case fixing screws loose, proceed to their tightness before avvhina.

The oil heaters should be placed at least 8 hours before starting. Make sure that the compressor crankcase is warm. Check that all valves in the refrigerant circuit are open. Check all equipment connected to the unit.

6.2 Start up

Start the unit by pressing the ON / OFF button. From the moment you give the request for unit start up, the moment at which you start the (first) compressor, will spend a fixed time. After switching off at the next start of the same compressor will spend a configured time set by the unit controller.

Check the direction of rotation of the fans and compressors. If wrong, reverse two phases of power. Make sure that all safety devices are working properly and control. Check the temperature of the water leaving the evaporator and adjust the settings of control. Check the oil level.

6.3 Start up of the plant per unit

During the operation of the system, in order to preserve each component of the machine and to optimize the use of the same, you need to get heat into the circuit before giving cooling energy to utilities.

To this end, it must operate in the following way:

- start the machine
- wait until the temperature of the inlet water to the unit is that of regime
- start utilities

Follow the above procedure at each stop of the plant, of such duration as to raise the temperature of the water contained in it.

6.4 Start up procedure

Unit start up (only authorized person)

1. With the switch closed, open the electrical panel and exclude compressor (refer to the wiring diagram on the machine). Close the panel, set switch to "ON" (to give power to the unit)
2. Wait for the start of the microprocessor and control. Make sure that the temperature of the oil is hot enough. The oil temperature must be at least 5 ° C higher than the saturation temperature of the refrigerant inside the compressor.
3. Place the unit in the "ON" and wait until the unit is indicated on the display-On.
4. Turn the pumps (if with inverter) at max speed.
5. Verify that the loss of load of the evaporator is equal to that of the project and correct if necessary. The loss must be recorded attacks on the charge placed on the evaporator piping and supplied as standard. Do not measure the load losses in points where they are interposed any valves and / or filters.
6. Check for air in cleaning Filters, and then draining the system.
7. Return the pump to the factory setting.
8. Turn off the power (into standby mode) and make sure the pumps stop after about 2 minutes.
9. Verify that the local temperature setpoint is set to the required value by pressing the Set button
10. Turn the main switch to "OFF". Open the cabinet. Reactivate the compressors. Close the cabinet. Turn the main switch to "ON" (to give power to the unit).
11. Wait for the start of the microprocessor and control. Just put in "ON" circuit # 1
12. When the compressor is started, wait about 1 minute for the system begins to stabilize.
13. Check the pressure of evaporation and condensation of refrigerant.
14. Check the fans start depending on the condensing pressure increase in chiller mode, on the evaporation pressure decrease in Recovery mode. In Chiller + Recovery mode fans are stopped.
15. Verify that, after a period of time necessary for the stabilization of the refrigerant circuit, the liquid indicator placed on the inlet pipe to the expansion valve is completely filled (no bubbles), and that the moisture indicator signs 'Dry'. The passage of bubbles within the liquid indicator, it may indicate a low amount of refrigerant, or an excessive pressure drop through the filter drier, or an expansion valve blocked at the maximum opening position.
16. In addition to checking the sight glass, check the operating parameters of the circuit controlling:
 - a. Overheating compressor suction
 - b. Overheating compressor discharge
 - c. Subcooling of the liquid exiting the condenser coils
 - d. Evaporation pressure
 - e. Condensing pressure

Measure the values of pressure and temperature instrumentation suitable vehicle with various pti indicated and make comparison by reading the corresponding values directly on the display of the microprocessor on board.

17. Repeat steps 11 to 16 for the second circuit.
18. To temporarily turn off the machine (turn off daily or weekend) put on standby the unit key, or open the remote contact (terminals shown in the wiring diagram provided with the machine) of the terminal X (Installing a remote switch by the customer), or set time zones. The microprocessor will activate the shutdown procedure that will take a few seconds. Two minutes after switching off the compressor will turn off the microprocessor / pump and / e. Do not remove the main power to not turn off the electrical resistances of the compressor and the evaporator.

Typical operating conditions with 100 working of compressors

ECONOMIZED CYCLE	SUNCTION SUPERHEATING	DISCHARGE SUPERHEATING	LIQUID SUPERHEATING
NO	5 – 7°C	20-25°C	5-6°C
SI	5 – 7°C	18-23°C	15-20°C

7 System maintenance

WARNING

All activities of ordinary and extraordinary maintenance on the machine must be carried out by qualified personnel who have been properly trained and familiar staff has the equipment, their operation, the correct procedures of assistance and knowing all the safety requirements as well as both aware of the dangers.

WARNING

The causes of repeated shutdowns due to the intervention of the safety devices must be investigated and corrected. The simple reset of alarm occurrences can lead to serious damage to the unit

WARNING

A proper charge of refrigerant and oil is essential for an optimal functioning of the machine and for the protection of the environment.
The recovery of oil and any refrigerant discharged from the unit must be carried out in accordance with regulations mvigenti.

7.1 General

WARNING

Beyond the cadences of checks recommended in the following, in order to keep the unit at optimum levels of performance and efficiency and prevent incipient failures, we recommend periodic visits of inspection and control of the unit by qualified personnel.

In particular, we recommend:

No. 4 annual visits to units that operate about 365 days / year (quarterly)

No. 2 visits per year for units with seasonal operation about 180 days / year (one start seasonal and a mid-season)

No. 1 annual visit for units with seasonal operation of about 90 days / year (starting seasonal)

It 'important that during the initial start-up and periodically during operation, carry out the checks and routine checks. Among them we must also check the suction and condensation as well as the sight glass located on the liquid line. Check through the microprocessor installed on the machine, the machine is working within normal parameters of superheating and subcooling. A routine maintenance program recommended is shown at the end of this chapter while a card collection of operating data is at the end of this manual. It is suggested to record on a weekly basis all the operating parameters of the machine. The collection of these data will be very useful to technicians, in case it is requested technical assistance.

Compressor Maintenance

WARNING

Although the single-screw compressor is of the semi-hermetic type and therefore does not need scheduled maintenance in order to keep the compressor at optimum levels of performance and efficiency and prevent incipient failures, it is recommended every 10,000 hours of operation, a check visual state of wear of the satellites and measuring the tolerances of satellite-lives. This inspection must be performed by qualified and trained personnel.

	Economized cycle??	Suction superheat	Overheating of discarghe	Liquid subcooling
The analysis of vibration is a great tool for checking the	NO YES	5-7°C 5-7°C	20-25 °C 18 -23 °C	5-6°C 15 -20 °C

mechanical conditions of the compressor.

It is recommended to check the value of the vibration immediately after starting and periodically on an annual basis. The compressor load will be similar to the previous load measurement for a reliability of measure.

7.2 Maintenance

The maintenance operations are essential to maintain the efficiency of the refrigeration unit, both from a purely functional and energy consumption. Each unit is equipped with a booklet on the machine, which will be provided by the user, or the person who is authorized on his behalf to the maintenance of the machine, return all records required in order to keep a historical record of the operation of the unit. The lack of records in the booklet will serve as evidence of poor maintenance.

7.3 Sight check of the under pressure vessels state

The risks due to the pressure inside the circuit have been eliminated or (when it is not possible) reduced by means of safety devices. It is important to check periodically the status of these devices and to carry out the components inspections and repositioning as follows.

Check at least once per year the under pressure vessels state.

It is important to check that the surface does not get rusty and that neither corrosion nor deformations are visible.

In case the superficial oxidation and the corrosion are not properly controlled and stopped in time, cause a thickness reduction with a consequent reduction of the vessel mechanical resistance.

Use antioxidant paint or products to protect.

7.4 Standard controls

Operations description	Recommended basis
Compressors oil level check	monthly
Inlet temperature check (overheating)	monthly
Water circuits filling check	monthly
Fans and compressors motors electrical input check	monthly
Power supply and auxiliary power voltage check	monthly
Refrigerant charge check through sight glass	monthly
Compressors carter heaters operation check	monthly
Tightening all electrical connections	monthly
Coils cleanliness	monthly
Compressors and liquid circuit solenoid valve check	semiannual
Adjusting and safety thermostat calibration check	Quarterly
Fans (if present) and compressors contactors state check	Quarterly
Evaporator heater operation check	Quarterly
Motor and fan (if present) bearing noise check	semiannual
Pressure vessels conditions check	yearly

Temperature and pressure probes

The unit comes factory-equipped with all the sensors listed below. Periodically check that their measurements are correct by means of sample instruments (manometers, thermometers); correct readings if necessary using the microprocessor keyboard. Well-calibrated sensors ensure better efficiency for the machine and a longer lifetime.

Note: refer to the microprocessor use and maintenance manual for a complete description of applications, setting and adjustments.

All sensors are preassembled and connected to the microprocessor. The descriptions of each sensor are listed below:

Outgoing water temperature sensor – This sensor is located on the evaporator outgoing water connection and is used by the microprocessor to control the machine's load according to the system's thermal load. It also performs the evaporator's antifreeze protection.

Ingoing water temperature sensor – This sensor is located on the evaporator ingoing water connection and is used for monitoring the return water temperature.

External air temperature sensor – Optional. This sensor allows to monitor the external air temperature on the microprocessor display. It is also used to carry out the “OAT setpoint override”.

Compressor delivery pressure transducer – This is installed on every compressor and allows to monitor the delivery pressure and to control the ventilators. Should a increase in condensation pressure arise, the microprocessor will control the compressor load in order to allow it to function even if choked. It contributes to complementing the oil control logic.

Oil pressure transducer - This is installed on every compressor and allows to monitor the oil pressure. Using this sensor, the microprocessor informs the operator on the conditions of the oil filter and on how the lubrication system is functioning. By working together with the high- and low-pressure transducers, it protects the compressor from problems deriving from poor lubrication.

Low-pressure transducer – This is installed on every compressor and allow to monitor the compressor intake pressure along with low pressure alarms. It contributes to complementing the oil control logic.

Intake sensor – This is installed optionally (if the electronic expansion valve has been requested) on each compressor, and allows to monitor the intake temperature. The microprocessor manages the electronic expansion valve control by means of this sensor.

Compressor discharge temperature sensor – This is installed on each compressor and allows to monitor compressor discharge temperature and oil temperature. The microprocessor controls liquid injection by means of this sensor and shuts down the compressor in case of alarm in the event that the discharge temperature reaches 110°C. It also protects the compressor from possible startups with liquid..

7.5 Unit test sheet

It is advisable to periodically detect the following operating data to verify the correct functionality of the machine in time. These data will also be of great benefit to the technicians who carry out routine maintenance and / or extraordinary machine.

Water side measurements

Chilled water setpoint °C _____
 Evaporator outgoing water temperature °C _____
 Evaporator ingoing water temperature °C _____
 Evaporator pressure drop kPa _____
 Evaporator water flow rate m³/h _____

Refrigerant side measurements

Circuit #1:
 Compressor Load _____ %
 N° of active Ventilators _____
 N° of expansion valve cycles (electronic only) _____
 Refrigerant/ Oils pressure
 Evaporation pressure _____ Bar
 Condensation pressure _____ Bar
 Oil pressure _____ Bar
 Refrigerant temperature Saturated evaporation temperature _____ °C
 Intake gas pressure _____ °C
 Intake overheating _____ °C
 Saturated condensation temperature _____ °C
 Delivery overheating _____ °C
 Liquid temperature _____ °C
 Undercooling _____ °C

Circuit #2
 Compressor Load _____ %
 N° of active Ventilators _____
 N° of expansion valve cycles (electronic only) _____
 Refrigerant/ Oils pressure
 Evaporation pressure _____ Bar
 Condensation pressure _____ Bar
 Oil pressure _____ Bar
 Refrigerant temperature Saturated evaporation temperature _____ °C
 Intake gas pressure _____ °C
 Intake overheating _____ °C
 Saturated condensation temperature _____ °C
 Delivery overheating _____ °C
 Liquid temperature _____ °C
 Undercooling _____ °C
 External air temperature

Electrical measurements

Analysis of the unit's voltage unbalance:

Phases: **RS** **ST** **RT**

_____ V _____ V _____ V

Unbalanced $\frac{V_{max} - V_{medio}}{V_{medio}} \times 100 = \text{_____ \%}$

Compressors current – Phases: **R** **S** **T**

Compressor #1 _____ A _____ A _____ A
 Compressor #2 _____ A _____ A _____ A

Funs Current i: #1 _____ A #2 _____ A
 #3 _____ A #4 _____ A
 #5 _____ A #6 _____ A
 #7 _____ A #8 _____ A

7.6 Recommended spare parts

There follows a list of the recommended parts for several years' running. Trane is at your disposal to recommend a personalised list of accessories according to the commissioned order, including the part number of the equipment

1 YEAR	
COMPONENTS	QUANTITY
Fuses	all
Drier filters	all
Solenoid valves	1 per type
Thermostatic or electronic valves	1 per type
Pressure switches	1 per type
Gas gauge	1 per type
Contactors and relays	1 per type
Thermal protectors	1 per type
Crankcase heaters	1 per type
Reversing valves	1 per type
Check valves	1 per type
Safety valves	1 per type
Sight glasses	1 per type
Fans	1 per type

2 YEARS	
COMPONENTS	QUANTITY
Fuses	all
Drier filters	all
Solenoid valves	all
Thermostatic or electronic valves	all
Pressure switches	all
Gas gauge	all
Contactors and relays	all
Thermal protectors	all
Crankcase heaters	all
Reversing valves	1 per type
Check valves	1 per type
Safety valves	1 per type
Sight glasses	1 per type
Fans and motors	1 per type
Electronic components	all
Compressors	1 per type

5 YEARS	
COMPONENTS	QUANTITY
Fuses	all
Drier filters	all
Solenoid valves	all
Thermostatic or electronic valves	all
Pressure switches	all
Gas gauge	all
Contactors and relays	all
Thermal protectors	all
Crankcase heaters	all
Reversing valves	all
Check valves	all
Safety valves	all
Sight glasses	all
Fans and motors	all
Electronic components	all
Compressors	all
Heat exchangers	1 per type

7.7 Improper use

The unit is projected and built up to grant the maximum safety in its proximity, as well as to resist to the aggressive environmental conditions. The fans are protected by grilles. Residual risks are indicated with warning labels.

SAFETY SYMBOLS



DANGER:
General danger

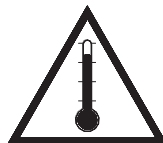

DANGER:
Temperature



DANGER:
Handling parts



DANGER:
Cut off voltage

7.8 Ordinary maintenance

Programmed maintenance

Activities list	week	Month (nota 1)	Year (nota 2)
General:			
Data collection operation (Note 3)	X		
Visually inspect the machine for any damage and / or looseness		X	
Verifying the integrity of the thermal insulation			X
Clean and paint where needed			X
Water Analysis (6)			X
electric:			
Check the correct operation of the equipment on the machine			X
Check the wear of contactors - Replace if necessary			X
Check tightness of all electrical terminals - Tighten if necessary			X
Clean the inside of the electrical panel			X
Visual inspection of the components for signs of overheating		X	
Check the operation of the compressor and the electric resistance		X	
Measurement using a Megger insulation of the compressor motor			X
Refrigerant circuit:			
Perform a test of refrigerant leaks		X	
Check through the sight glass coolant flow - Full Indicator	X		
Check the pressure drop of the filter drier		X	
Check the pressure drop of the oil filter (Note 5)		X	
Carry out the analysis of the vibrations of the compressor			X
Carry out the analysis of the acidity of the oil of the compressor (7)			X
Condensing section:			
Cleaning the condenser coils (Note 4)			X
Check that the fans are tightened			X
Check the fins of batteries - Pettinarle if necessary			X

Notes:

- 1) The monthly activities include all those weekly
- 2) The annual activity (or earlier in the season), include all activities weekly and monthly
- 3) The values of the machine should be recorded each day for a high level of observation.
- 4) The coil cleaning may be required more frequently in areas with a high percentage of particles in the air.
- 5) Replace the oil filter when its pressure drop reaches 2.0 bar
- 6) Check for dissolved metals
- 7) TAN (Total Acid Number):

≤ 0.10:	No action
From 0.10 to 0.19:	Repositioning filters antacid and occurs after 1000 hours of operation. Continue to replace the filters until the TAN not falls below 0.10.
> 12:19:	Changing the oil, oil filter and the filter drier, Refer to regular intervals.

regular intervals.

7.9 Dehydration filter repositioning

It is recommended the repositioning of filter cartridges Dryer in the case of high pressure drop across the filter same or in case with the value of the subcooling within the limits of acceptability, occurs the passage of bubbles through the sight glass.

It suggests the repositioning of the cartridges when the pressure drop across the filter reaches 50 kPa with the compressor at full load.

The cartridges must also be replaced when the humidity indicator inside the sight glass changes color and highlight excessive humidity, or the periodic oil analysis indicates the presence of acidity (TAN excessive)

Repositioning Procedure

WARNING

Ensure proper water flow through the evaporator throughout the intervention period. The interruption of the flow water during this procedure would result in the freezing of the evaporator resulting in rupture of the its internal pipes.

1. Switch off the compressor by turning the corresponding switch in the Off
2. Wait until the compressor has stopped and close the valve located on the liquid line
3. Start the compressor by turning the corresponding switch to On
4. Verify on the display of the microprocessor, the evaporation pressure corresponding.
5. When the vapor pressure reaches 100 kPa rotate the switch again to switch off the compressor.
6. Once the compressor is stopped by putting a label on the switch for starting the compressor maintenance to prevent unwanted ignitions.
7. Close the suction valve of the compressor (if any)
8. With a recovery unit to remove the remaining refrigerant from the filter of the liquid, until the atmospheric pressure. The refrigerant must be stored in a suitable container and clean.

WARNING

To protect the environment, do not release the refrigerant into the atmosphere removed. Always use a device recovery and storage.

9. Balance the internal pressure with the outside by pressing the vacuum valve installed on the the filter cover.
10. Remove the cover from the filter drier.
11. Remove the filter elements.
12. Install the new filter elements within the filter.
13. Replace the cover gasket. Do not oil the filter gasket with mineral oil to non-contamination in the circuit. Use for this purpose only compatible oil (POE)
14. Close the filter cover.
15. Connect the vacuum pump to the filter and evacuate up to 230 Pa.
16. Close the valve on the vacuum pump.
17. Recharge the refrigerant recovered in the filter during its emptying.
18. Open the valve on the liquid line.
19. Open the suction valve (if any).
20. Start the compressor by turning the switch.

7.10 Oil Filter repositioning

▲ WARNING

The lubrication system is designed to maintain the majority of the charge of oil inside the compressor. However, during operation, a limited amount of oil circulates freely within the system, transported from the refrigerant. Therefore, the amount of oil to enter into the compressor will have to be equal to that removed and not the

total amount of plaque to prevent excessive amount of oil start next.

The measurement of the amount of oil removed from the compressor, must be carried out after leaving evaporate the refrigerant contained in the oil itself for a period of time adequate. To minimize the content of refrigerant in the oil, it is recommended to leave the heating elements on and to remove the oil when the latter has reached a temperature of $35 \pm 45^\circ \text{C}$.

▲ WARNING

The repositioning of the oil filter requires special care in the preservation of the oil may be removed; being extremely hygroscopic, it must not be exposed to air for a period not exceeding 30 minutes about.

If in doubt, check the acidity of the oil or, where such a measure to change the oil with another taken from sealed container or stored according to manufacturer's specifications.

The compressor oil filter is located under the oil separator pressure side. He recommends repositioning when its pressure drop exceeds 2.0 bar. The pressure drop through the oil filter is given by difference between the discharge pressure of the compressor less the oil pressure. Both of these pressures can be controlled by the microprocessor for both compressors.

Ask the manufacturer to supply more information and filter what is necessary for its repositioning.

Oil filter repositioning procedure

1. Turn off both compressors turning the switches in the off position.
2. Turn the main switch OFF wait until the circulation pump and open the switch general to remove the power supply to the machine.
3. Put a plate on the handle of the main switch to prevent accidental starting.
4. Close the valves of suction, discharge and liquid injection.
5. Connect the recovery unit to recover the refrigerant compressor and within an adequate and clean storage container.
6. Evacuate the refrigerant until the pressure inside has achieved a negative pressure (compared atmospheric pressure). With this reduces to a minimum the amount of refrigerant dissolved in the oil.
7. Remove the oil contained in the compressor by opening the drain cock located below the engine.
8. Remove the oil filter cover and remove the filter element inside.
9. Replace the O-ring of the lid and the inner sleeve. Do not lubricate the O-ring with mineral oil to non-pollute the system.
10. Insert the new filter element.
11. Replace the lid of the filter and tighten the screws. The screws should be tightened alternately progressively tightening torque 60Nm.
12. Load the oil from the top cap placed on the oil separator. Given the high hygroscopicity foreign oil, the Oil filling must be done in the shortest possible time. Do not leave the ester oil exposed atmosphere for a time greater than 10 minutes.
13. Close the oil filler cap.
14. Connect the vacuum pump and evacuate the compressor up to a vacuum of 230 Pa.
15. On reaching the vacuum level predicted close the valve on the vacuum pump.
16. Open the valves, suction and liquid injection system
17. Disconnect the vacuum pump from the compressor.
18. Remove the plate WARNING located on the switch.
19. Close the main switch to power the machine.
20. Start the machine according to the starting procedure described above.

Refer to cap. 4, par 4.4.

7.11 Disposal

Unit disconnection

The unit disposal must be performed by qualified personnel.

Pay attention not to disperse harmful liquid or gases.

Recover as much refrigerant gas as possible from the unit and any freezing solution in the water circuits.

Decommissioning and disposal

At disposal, heat exchangers, finned batteries, fans or motors may be recovered if working.

All non-recoverable materials are to be disposed of in accordance with current standards and regulatory requirements.

8 Service and limited warranty

Warranty is based on the general terms and conditions of the manufacturer. The warranty is void if the equipment is repaired or modified without the written approval of the manufacturer, if the operating limits are exceeded or if the control system or the electrical wiring is modified. Damage due to misuse, lack of maintenance or failure to comply with the manufacturer's instructions or recommendations is not covered by the warranty obligation. If the user does not conform to the rules of this manual, it may entail cancellation of warranty and liabilities by the manufacturer.

9 Important information regarding the refrigerant used

This product contains fluorinated greenhouse gases covered by the Kyoto Protocol.

Do not vent into the atmosphere.

Type of refrigerant: R134a

GWP (1) 1300

(1) GWP = global warming potential

The amount of refrigerant is indicated on the name plate of the unit.

You may be required Periodical inspections for refrigerant leaks according to the local regulations and / or European.

For more detailed information, contact your local dealer.

10 Plant sketches

10.1 Plant sketches standard version

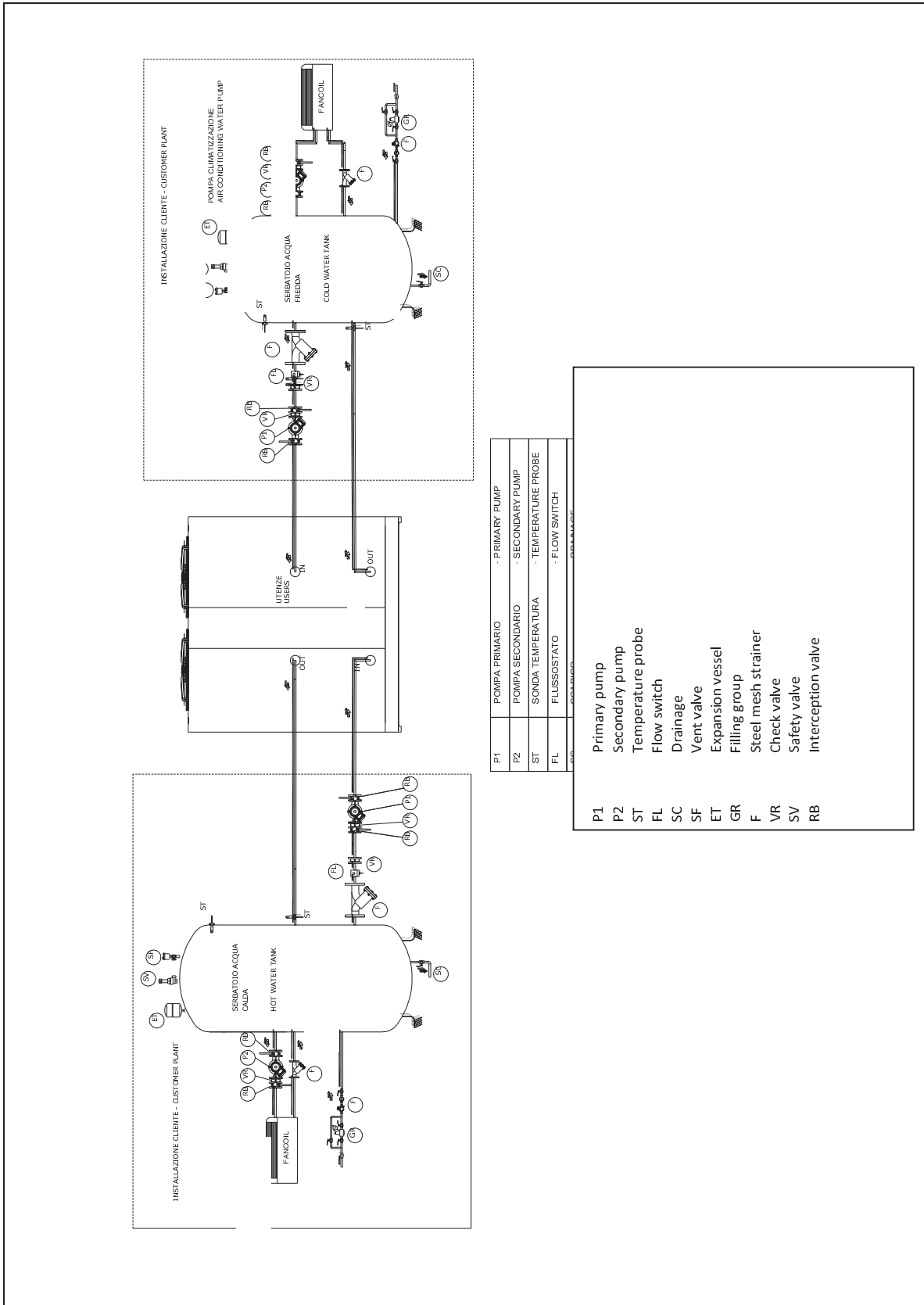

10.2 Plant sketches for single pump version

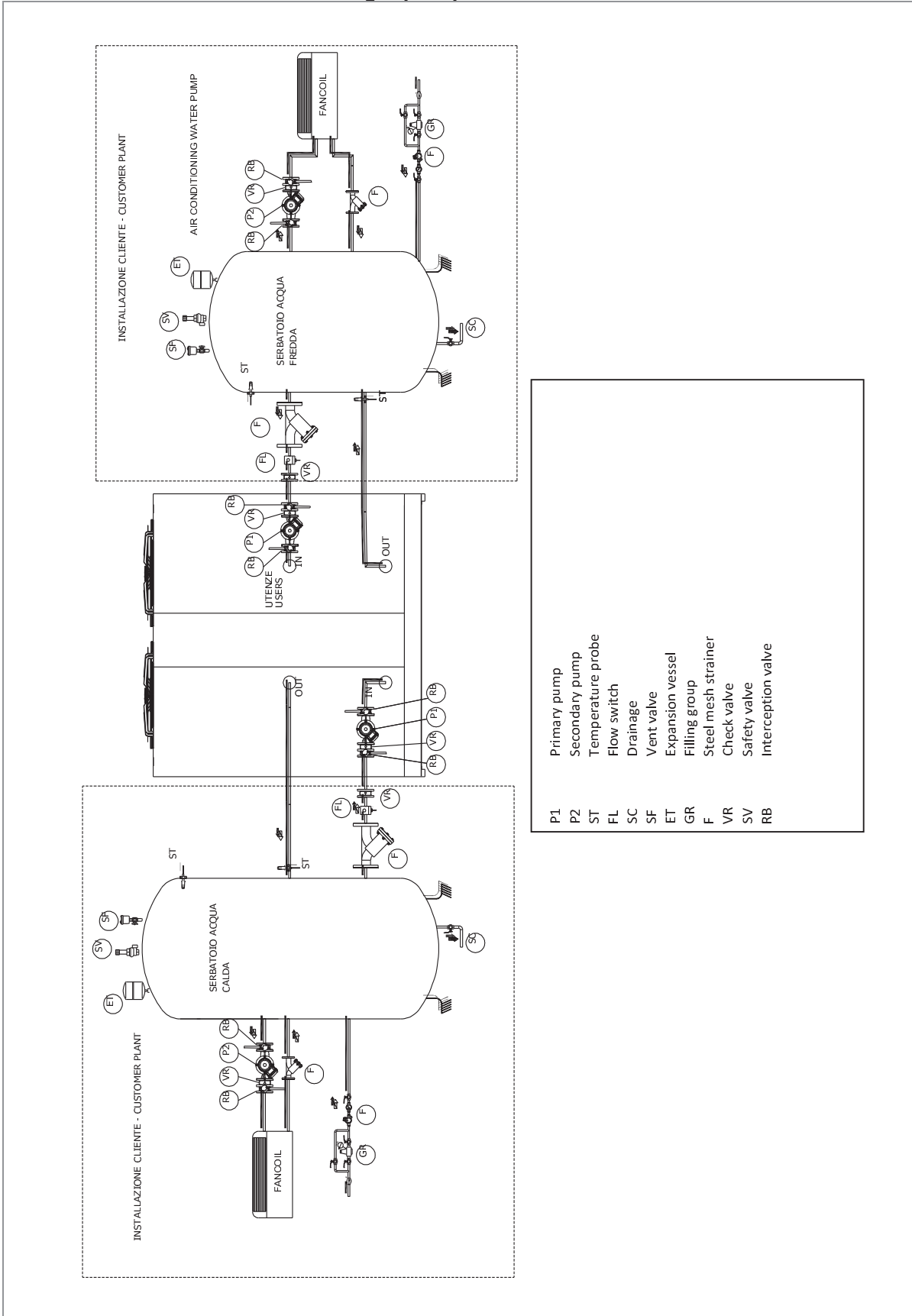

10.3 Plant sketches for single pump + stand by pumps version

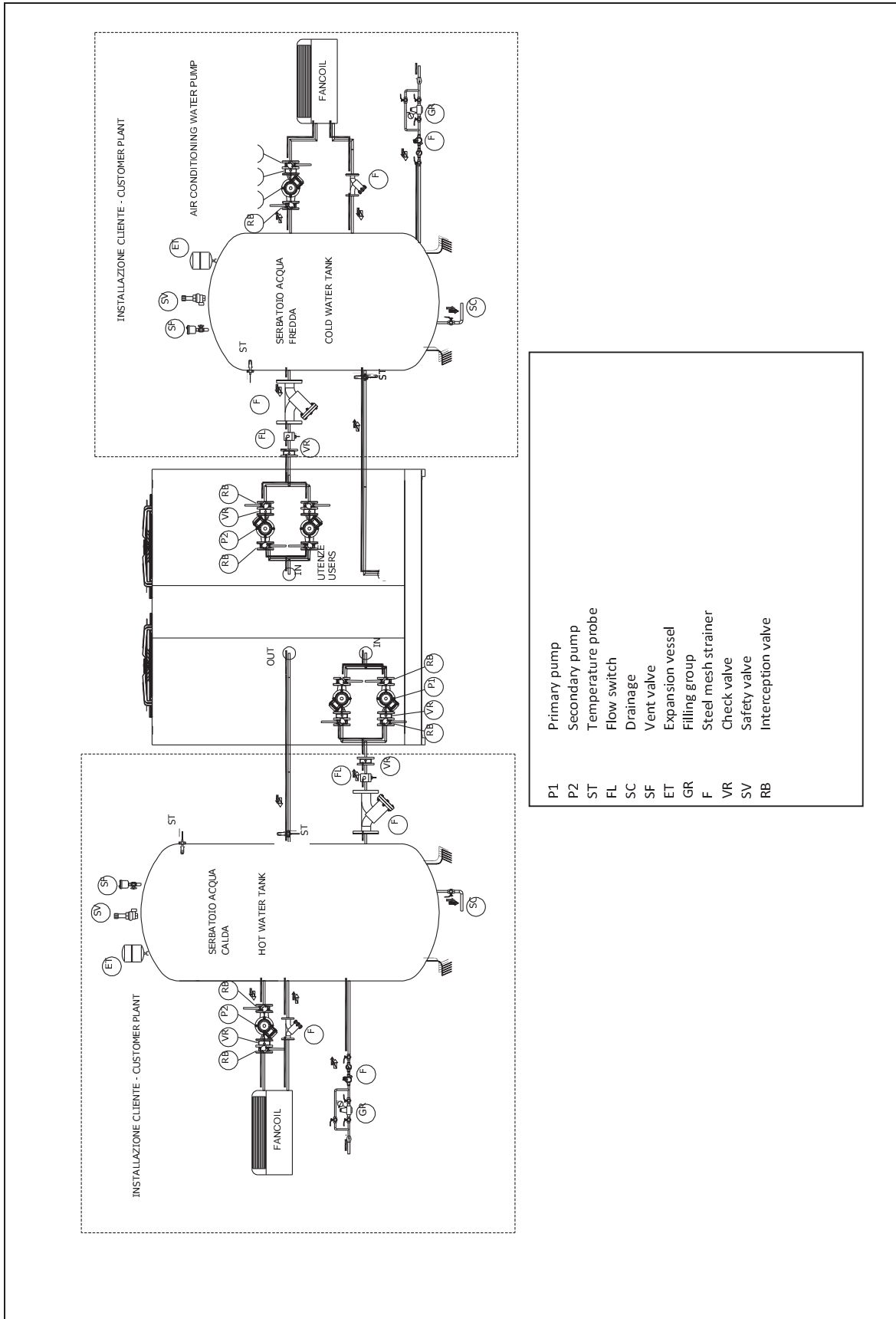

Check for hot and cold accumulation, and their proper installation according to the diagrams above.
For the purposes of an optimal operation of the machine, especially for departures to produce hot water at low temperatures in which the machine can 'be outside or in the vicinity' of the allowable range (see technical data sheets).
Before a stationary machine with temperatures close to 0 ° C, to provide compressed air to evacuate the contents of the exchanger in order to prevent breakage caused by ice formation.
And 'possible to connect the unit due to the build-up with simple coil or double coil, to heat integration or already' existing in this case and 'on the hot side must install a diverter valve V3 and a non-return valve for VR prevent excessively hot water may damage the machine.

10.4 Hydraulic connections

Preamble

The connecting pipes should be adequately supported so as not to burden with their weight on the system.
The installation instructions included in the statements to follow, represent a necessary condition for the validity of the guarantee.
Trane is at your disposal to examine any differing needs, which still must be approved prior to the operation of the unit.
It is necessary that the water flow to the group is compatible with that of the evaporator. It is also necessary that the water flow is maintained constant during operation

Dimensioning of the minimum water content and flow

*To function properly, the unit needs a water content sufficient to avoid continuous changes of the cycle or shutdown and restart the compressor too frequently (refer to the contents in this manual) tab p .. Refer to the general technical data chapter. The content can be reduced by the quantity declared 'contained in the piping distribution system as regards the only air conditioning system. Accumulations undersized reduce the useful life of the machine design.
For a correct operation of the unit, it is absolutely necessary to ensure a constant Portat to the machine; especially in case of lack of accumulations is recommended to mount between the delivery branch and return pump volvola a by pass automatic or manual valve or appropriately set in phase the commissioning of the machine.*

WARNING: it is recommended to mount on the side water overflow valves to prevent dangerous overpressure and / or water hammer.

Apparatus for adjusting the water circuit

Or monoblock centrifugal electric pump.
Ensures the scope and prevalence needed to power the evaporator shell and tube or plate, storage and utilities.

Automatic filling unit
Ensures the maintenance of water pressure in the system at least 1.5 bar automatically topping.

Safety valve
Undertakes to open atmosphere in the system if the pressure exceeds 6 bar.

Expansion vessel
Compensates for small water hammer and volume changes for different temperatures.

Shut-off valves
Provide to intercept the pump or other components for maintenance.

Non-return valves
Take steps to ensure the direction of water flow and also have the function of preventing the propagation of heat downstream of the plant when its pump is switched off.

11. Dimensional Drawing and weight

RTMA 105 - 115

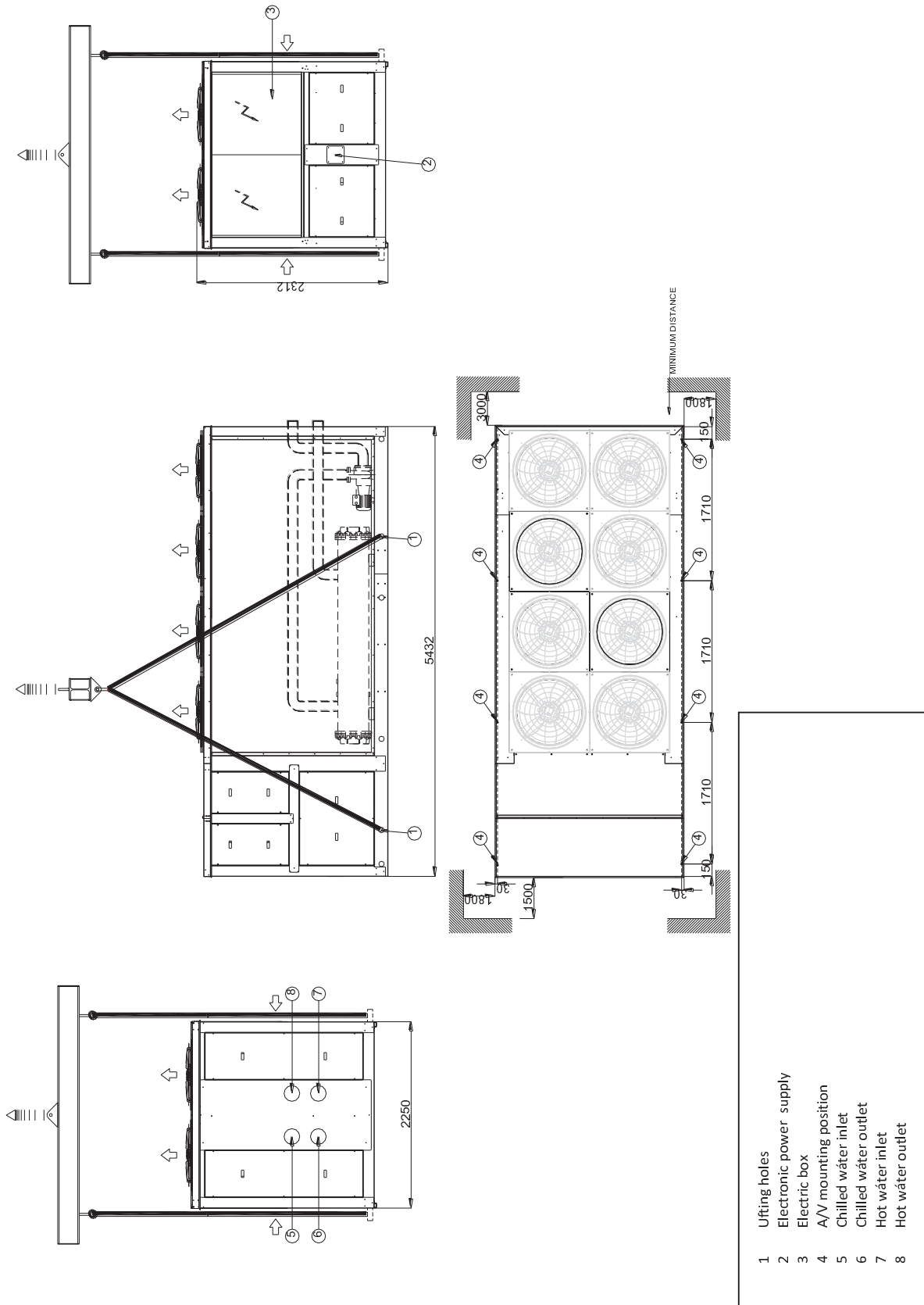

INSTALLATION OPERATION MAINTENANCE

Operation weights		105	115
Basic Version	kg	5592	5799
Tubes diameter			
⑤ - ⑥	∅	5" VICTAULIC	5" VICTAULIC
⑦ - ⑧	∅	5" VICTAULIC	5" VICTAULIC
Operation weights for hydraulic version			
Single pump 150 kPa head pressure	kg	5903	6110
Double pump 150 kPa Head pressure	kg	6149	6356
Single pump 250 kPa head pressure	kg	5949	6156
Double pump 250 kPa Head pressure	kg	6241	6448
Single pump 450 kPa head pressure	kg	5991	6198
Double pump 450 kPa Head pressure	kg	6325	6532
Operation weights for acoustic version			
LN	kg	5592	5799
SL	kg	5872	6079
Single pump 150 kPa head pressure + SL	kg	6183	6390
Double pump 150 kPa Head pressure + SL	kg	6429	6636
Single pump 250 kPa head pressure + SL	kg	6229	6436
Double pump 250 kPa Head pressure + SL	kg	6521	6728
Single pump 450 kPa head pressure + SL	kg	6271	6478
Double pump 450 kPa Head pressure + SL	kg	6605	6812

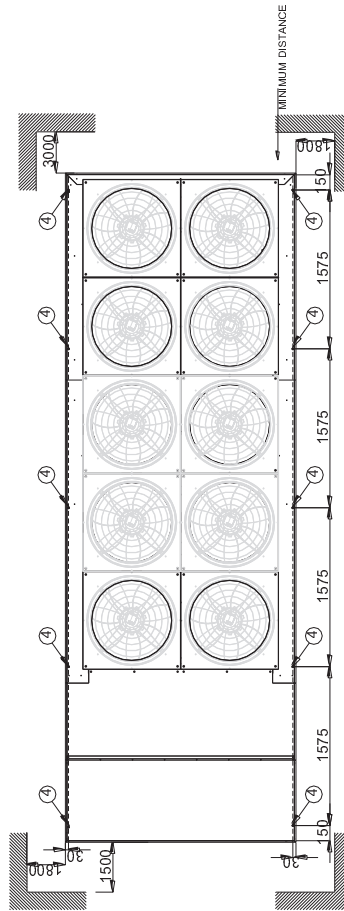
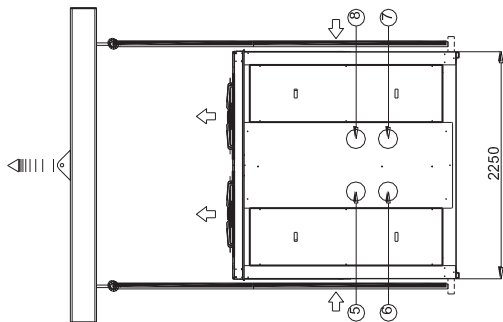
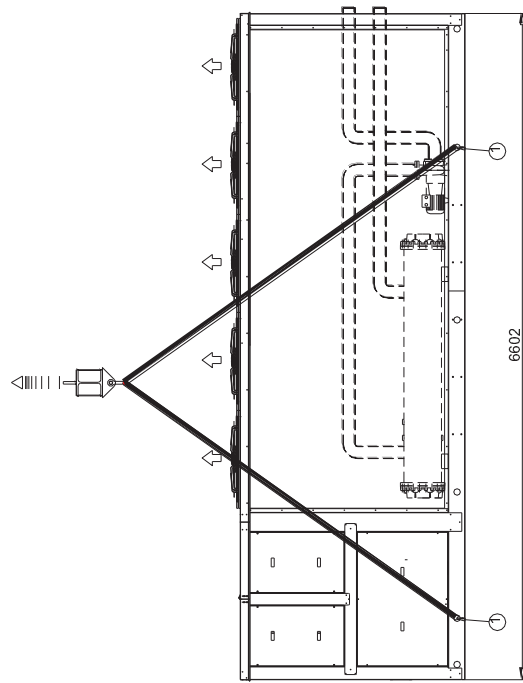
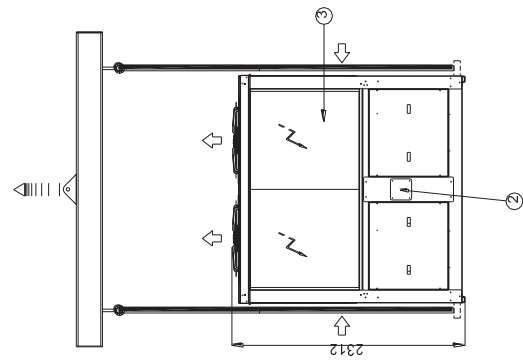
RTMA 120 – 130

- 9 Ufing holes
- 10 Electronic power supply
- 11 Electric box
- 12 A/V mounting position
- 13 Chilled water inlet
- 14 Chilled water outlet
- 15 Hot water inlet
- 16 Hot water outlet

INSTALLATION OPERATION MAINTENANCE

Operation weights		120	130
Basic Version	kg	6057	6121
Tubes diameter			
⑤ - ⑥	∅	5" VICTAULIC	5" VICTAULIC
⑦ - ⑧	∅	5" VICTAULIC	5" VICTAULIC
Operation weights for hydraulic version			
Single pump 150 kPa head pressure	kg	6368	6517
Double pump 150 kPa Head pressure	kg	6614	6831
Single pump 250 kPa head pressure	kg	6414	6529
Double pump 250 kPa Head pressure	kg	6706	6855
Single pump 450 kPa head pressure	kg	6456	6571
Double pump 450 kPa Head pressure	kg	6790	6939
Operation weights for acoustic version			
LN	kg	6057	6121
SL	kg	6387	6451
Single pump 150 kPa head pressure + SL	kg	6698	6847
Double pump 150 kPa Head pressure + SL	kg	6944	7161
Single pump 250 kPa head pressure + SL	kg	6744	6859
Double pump 250 kPa Head pressure + SL	kg	7036	7185
Single pump 450 kPa head pressure + SL	kg	6786	6901
Double pump 450 kPa Head pressure + SL	kg	7120	7269

RTMA 150 – 180

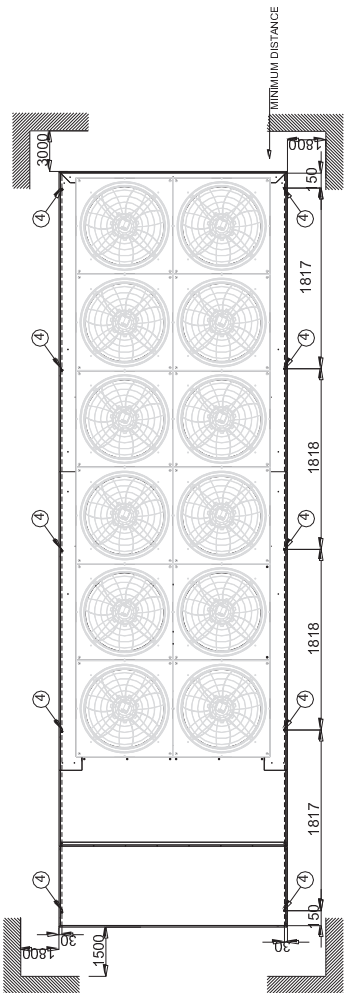
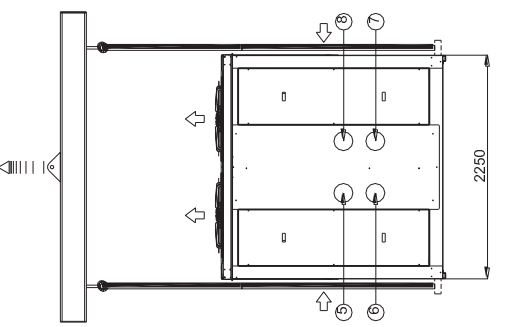
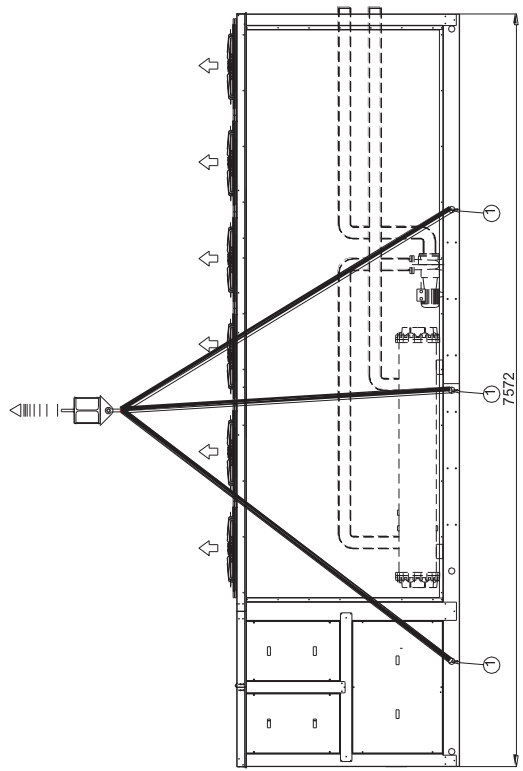
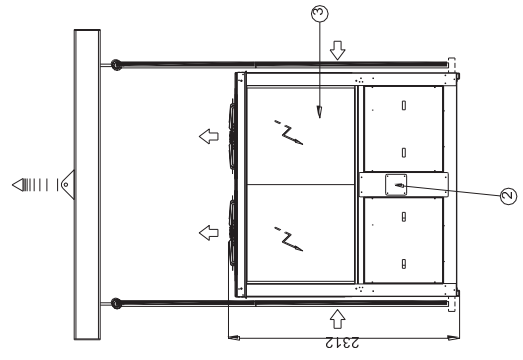

- 17 Lifting holes
- 18 Electronic power supply
- 19 Electric box
- 20 A/V mounting position
- 21 Chilled water inlet
- 22 Chilled water outlet
- 23 Hot water inlet
- 24 Hot water outlet

INSTALLATION OPERATION MAINTENANCE

Operation weights		150	170	180
Basic Version	kg	6578	6925	6946
Tubes diameter				
⑤ - ⑥	∅	5" VICTAULIC	5" VICTAULIC	6" VICTAULIC
⑦ - ⑧	∅	5" VICTAULIC	6" VICTAULIC	6" VICTAULIC
Operation weights for hydric version				
Single pump 150 kPa head pressure	kg	7010	7411	7432
Double pump 150 kPa Head pressure	kg	7360	7797	7818
Single pump 250 kPa head pressure	kg	6986	7499	7520
Double pump 250 kPa Head pressure	kg	7312	7973	7994
Single pump 450 kPa head pressure	kg	7028	7769	7790
Double pump 450 kPa Head pressure	kg	7396	8513	8534
Operation weights for acoustic version				
LN	kg	6578	6925	6946
SL	kg	6948	7295	7316
Single pump 150 kPa head pressure + SL	kg	7380	7781	7802
Double pump 150 kPa Head pressure + SL	kg	7730	8167	8188
Single pump 250 kPa head pressure + SL	kg	7356	7869	7890
Double pump 250 kPa Head pressure + SL	kg	7682	8343	8364
Single pump 450 kPa head pressure + SL	kg	7398	8139	8160
Double pump 450 kPa Head pressure + SL	kg	7766	8883	8904

RTMA 190 – 210

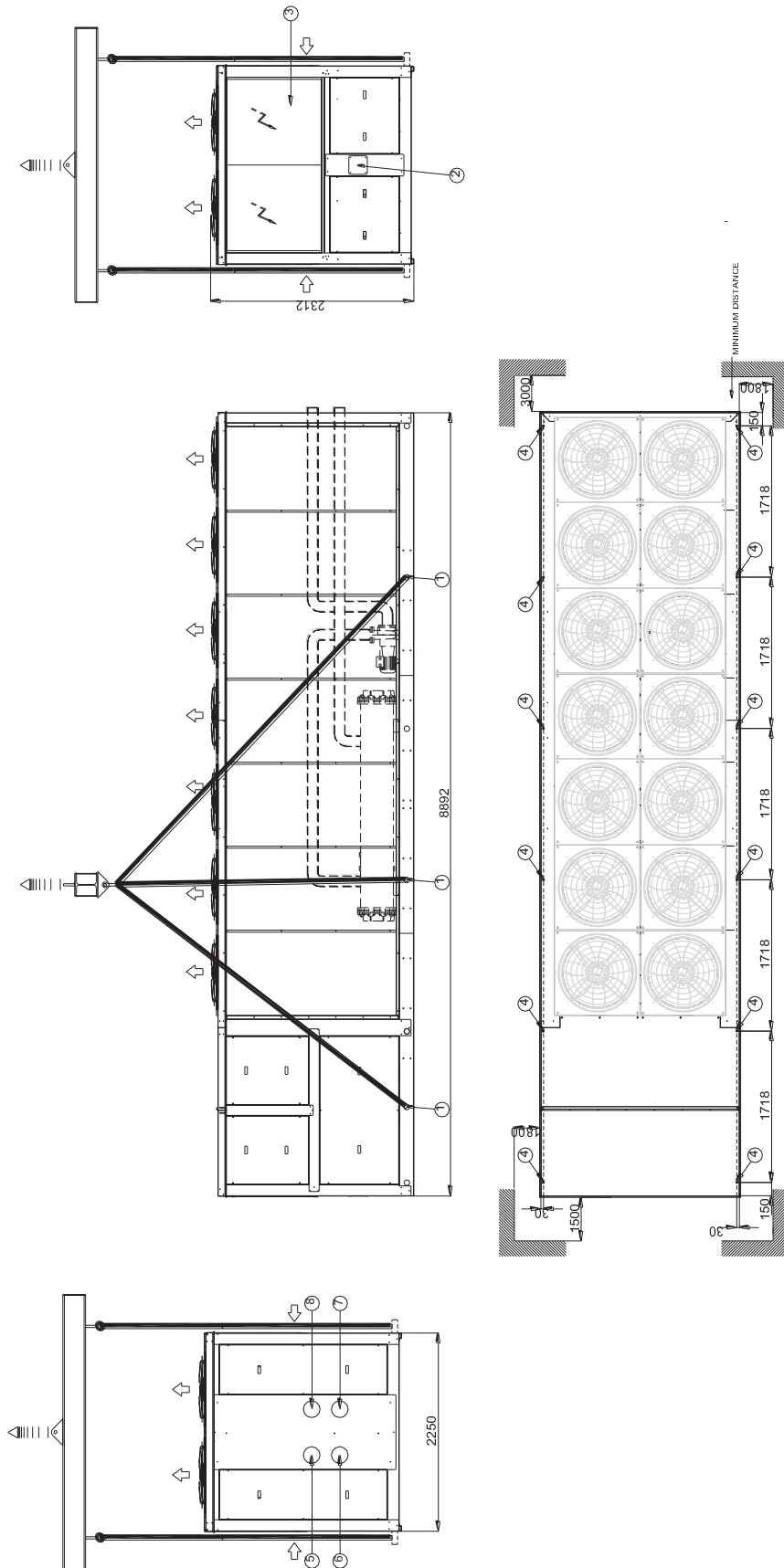

- 25 Ufting holes
- 26 Electronic power supply
- 27 Electric box
- 28 A/V mounting position
- 29 Chilled water inlet
- 30 Chilled water outlet
- 31 Hot water inlet
- 32 Hot water outlet

INSTALLATION OPERATION MAINTENANCE

Operation weights		190	210
Basic Version	kg	7199	7794
Tubes diameter			
⑤ - ⑥	∅	6" VICTAULIC	6" VICTAULIC
⑦ - ⑧	∅	6" VICTAULIC	6" VICTAULIC
Operation weights for hydric version			
Single pump 150 kPa head pressure	kg	7733	8328
Double pump 150 kPa Head pressure	kg	8151	8746
Single pump 250 kPa head pressure	kg	7821	8416
Double pump 250 kPa Head pressure	kg	8327	8922
Single pump 450 kPa head pressure	kg	8091	8686
Double pump 450 kPa Head pressure	kg	8867	9462
Operation weights for acoustic version			
LN	kg	7199	7794
SL	kg	7619	8214
Single pump 150 kPa head pressure + SL	kg	8153	8748
Double pump 150 kPa Head pressure + SL	kg	8571	9166
Single pump 250 kPa head pressure + SL	kg	8241	8836
Double pump 250 kPa Head pressure + SL	kg	8747	9342
Single pump 450 kPa head pressure + SL	kg	8511	9106
Double pump 450 kPa Head pressure + SL	kg	9287	9882

12. TROUBLESHOOTING

In this section you will find a list of the most common problems that may cause the chiller unit to stop or malfunction. Possible remedies are shown alongside a description of easily identifiable remedies.

Warning! Extreme care should be taken when performing work or repairs on the unit: overconfidence can result in injuries, even serious ones, to inexperienced individuals. Operations marked with the letter "U" can be performed directly by the user, who must carefully follow the instructions provided in this manual. Operations marked with the letter "S" may be performed exclusively by specialised personnel.

Once the cause has been identified, you are advised to contact a Trane service centre or a qualified technician for help.

SYMPTOM	cooling	heating	Who can take corrective action U = User S = specialised personnel	Probable cause	Possible remedy
A The unit does not start	X	X	S	Faulty connection or open contacts	Check the voltage and close contacts
	X	X	S	Lack of external consents	Check the operation of the water pump, the pressure switch, vent the system;
	X	X	U	Anti-recycle timer active	Wait 5 minutes for the timer gives consent
	X	X	S	Probe faulty service	Check and replace if necessary
	X	X	U	Lack of consent of the service thermostat	Plant in temperature, lack of demand; verify calibration
	X	X	U	Lack of consent of the frost protection thermostat	Check water temperature Check the calibration of the anti-
	X	X	S	Frost sensor defective	Check the operation
	X	X	S	Tripped breaker general	Check if there are any short circuits in the wiring or in the windings of the motors of pump, fan, compressor, and the transformer.
	X	X	S	Lack of consent of the high or low pressure	See points D-E
				Defective compressor	See point B
B The compressor does not start	X	X	S	Compressor burnt or seized	Replace the compressor
	X	X	S	Compressor contactor de-energized	Check the voltage across the coil of the compressor contactor and the continuity of the coil
	X	X	S	Power circuit open	Investigate the cause of the protection, and check if there are any short circuits in the wiring or in the windings of the motors of pump, fan, compressor and transformer
	X	X	S	Motor thermal protection open	The compressor has operated in critical condition or there is a lack of charge in the circuit: Make sure that working conditions are within the limits of operation. Loss of coolant: see section G
C The compressor starts up and stops repeatedly	X	X	S	Intervention of the minimum	See point E
	X	X	S	Compressor contactor defective	Check and replace if necessary
	X	X	U	Calibration values of the set-point or differenzialeerrati	Modify them as reported in the tables.
	X	X	S	Lack of coolant	See point G
D The compressor does not start because the maximum pressure switch has tripped	X	X	S	Pressure switch out of order	Check and replace
	X	X	S	Overcharge of refrigerant	Download the excess gas
	X		U	Finned coil clogged, air flow rate is too low	Remove dirt from the battery and obstructions to the airflow.
	X		S	Fan not working	See point F
		X	U	Water circulation pump blocked	Unlock the pump
		X	S	Water circulation pump defective	Check the pump and replace if necessary.
	X	X	S	Presence of non-condensable gases in the refrigerating circuit	Prime the circuit after it has been downloaded and put under vacuum
X	X	S	Refrigerant filter clogged	Check and replace	

INSTALLATION OPERATION MAINTENANCE

SYMPTOM	cooling	heating	Who can take corrective action U = User S = specialised personnel	Probable cause	Possible remedy
E The compressor does not start because the minimum pressure switch has tripped	X	X	S	Pressure switch out of order	Check and replace
	X	X	S	Machine completely download	See point G
		X	U	Finned coil clogged, air flow rate is too low	Remove dirt from the battery
	X		U	Water circulation pump blocked	Unlock the pump
	X		S	Water circulation pump blocked defective	Check the pump and replace if necessary.
		X	S	Presence of frost on evaporator coil	See point O
		X	S	Evaporator fan not working	See point F
	X	X	S	Refrigerant filter clogged	Check and replace
	X	X	S	Expansion device that is not working properly	Check and if necessary replace
F The fans do not start	X	X	S	Fan contactor de-energized	Check the voltage across the coil of the contactor and the continuity of the coil
	X	X	S	Lack of output voltage from the control fan speed	Check the contacts, replace if necessary
	X	X	S	Thermal protection inside the fan	Check the condition of the fan and the air temperature during operation of the machine.
	X	X	S	Fan motor faulty	Check and replace
	X	X	S	Loose electrical connections	Check and secure
G Lack of gas	X	X	S	Loss in the refrigerant circuit	Check the cooling circuit using a leak detector after pressurising the circuit to approximately 4 bars. Repair, evacuate and refill.
I Frost in liquid pipe downstream from a filter	X	X	S	The liquid filter is clogged	Replace the filter
L The unit works continuously without ever stopping	X	X	S	Lack of refrigerant gas	See item G.
	X	X	U	Incorrect tuning of the operating thermostat	Check the setting
	X	X	S	Excessive thermal load	Reduce the thermal load
	X	X	S	Compressor does not give the thermal output	Check, change or revise
	X	X	S	The liquid filter is clogged	Replace
M The unit works regularly but with an insufficient capacity	X	X	S	Low refrigerant charge	See point G
	X	X	S	4-way reversing valve defective	Check the power supply and the coils of the valve and replace the valve
N Frost in the compressor intake pipe	X	X	S	Expansion device that is not working properly	Verify replace
	X		S	Water circulation pump blocked	Unlock the pump
	X	X	S	Water circulation pump defective	Check the pump and replace if necessary
	X	X	S	Low refrigerant charge	See point G
	X	X	S	The liquid filter is clogged	Replace
O The defrosting cycle is never activated		X	S	4-way reversing valve defective	Check the power supply and the coil of the valve and replace the valve
		X	S	The defrost thermostat is worn out or has an incorrect calibration value	Check and replace if defective or change the calibration value
P Abnormal	X	X	S	Compressor noisy	Check and replace if necessary

noises detected in the system	X	X	S	The panels vibrate	Fasten properly
Q THE UNIT DOES NOT START	X	X	s	phases of the supply network reversed	Invert phases



Trane optimizes the performance of homes and buildings around the world. A business of Ingersoll Rand, the leader in creating and sustaining safe, comfortable and energy efficient environments, Trane offers a broad portfolio of advanced controls and HVAC systems, comprehensive building services, and parts. For more information, visit www.Trane.com.

Trane has a policy of continuous product and product data improvement and reserves the right to change design and specifications without notice.